

Europe

Italy

CHINT Electrics Europe S.R.L.

Add: Via A. Pacinotti 28, 30033 Noale (VE)
Tel: 0039 335 6265 032
E-mail: chint_eu@chint.com

Czech Republic

NOARK Electric Europe s.r.o.

Add: Sezemická 2757/2, 193 00 Prague
Tel: +420 226 203 120
Email: Europe@noark-electric.com
www.noark-electric.eu

North America

United States

NOARK Electric (USA) Inc.

Add: 2188 Pomona Blvd., Pomona, CA 91767
Tel: 626-330-7007
Fax: 626-330-8035
E-mail: nasales@noark-electric.com
na.noark-electric.com

West Asia & Africa

U.A.E

CHINT West Asia & Africa FZE

Add: Office NO. LB182406, P.O.Box:263174, Jebel Ali, Dubai,
United Arab Emirates
Tel: 00971-48848286
Fax: 00971-48848287
E-mail: chintwaa@chint.com

Spain

CHINT Electrics S.L.

Add: Calle José Echegaray, Num 8, Parque Empresarial Las Rozas
Edificio 3, Planta 1º, Oficina 3.C.P: 28232 Las Rozas (Madrid)
Tel: 0034 91 636 59 98
Fax: 0034 91 645 95 82
E-mail: info@chintelectrics.es

Russia

ООО «Чинт Электрик»

Адрес: РФ, 109089, г. Москва, ул. Угрешская, д.2, стр.3, оф.17
Тел.: +7 495 665 6340
Факс: +7 495 665 6340
Email: cis@chint.com

Latin America

Brazil

CHINT Electrics South America Ltd

Add: Avenida Paulista nº 2073 – Conjunto Nacional – Edifício Horsa 1-
Conjunto Room 1407/1408, Sao Paulo 01311-300
Tel: 0055-11-3266-7654
Fax: 0055-11-3142-9601
E-mail: chintlatinamerica@chint.com; xjie@chint.com

Asia Pacific

China

Zhejiang CHINT Electrics Co., Ltd

Add (Shanghai): Bldg.2, No.3255 Sixian Road, Songjiang 201614 P.R.China
Tel: 0086-21-67777706
Fax: 0086-21-67777777-88225
E-mail: asiapacific@chint.com, lwgen@chint.com



CHINT
CHINT ELECTRIC

ZHEJIANG CHINT ELECTRICS CO.,LTD.

Add: No. 1, CHINT Road, CHINT Industrial Zone, North Baixiang,
Yueqing, Zhejiang, 325603, P.R.China
Tel: +86-4001177797
Fax: +86-577-62775769 62871811
E-mail: AsiaPacific@chint.com lwgen@chint.com
Website: http://next.chint.com/



© CHINT Electric All Rights Reserved

Recycle Paper Printed

Specifications and technical data are subject to change without notice.
Please contact us to confirm relevant information on ordering



May 2017

© CHINT . NO . EN K03

CHINT | Next
CHINT ELECTRIC | series

The Next Reliable Choice

Air Circuit Breaker

CHINT•Empower the World



Founded in 1984, CHINT Group is a leader in Chinese industrial electric appliance and new energy sectors. With total assets of 36.5 billion RMB and nearly 30 thousand employees, the company is running business that covers the whole power equipment industrial chain including power generation, transmission, transformation, distribution, and consumption. The company is also operating in the fields of urban rail traffic, energy equipment manufacturing, new energy storage materials, Energy Internet, investment & financing platform, and business incubator. The products have been sold to over 120 countries and regions around the world, and have entered main component markets in Europe, Asia, Middle East, and Africa.

The group ranks among top 500 private enterprises in China, and has been the largest tax payer among all manufacturers in Wenzhou for a few consecutive years. Zhejiang CHINT Electric Appliance Corporation under CHINT Group is the largest company in domestic LV electric appliance industry in terms of production and sales amount, and also the first company running LV electric appliance as main business listed in A-share market. CHINT Solar has built over a hundred photovoltaic power stations around the world, serving as the largest photovoltaic power station investor and operator in all domestic private players.

CHINT has always following the policies of innovation-driven industrial development. It's the first among all competitors to pass ISO9001 quality system certification, ISO 14001 environment system certification, and OHSAS18001 occupational health safety management certification. The group also holds China Compulsory Certificate (CCC), international CB safety certificate, US UL certificate, Finland FI certificate, Belgium CEBEC certificate, Netherland KEMA certificate, and Germany VDE certificate. The group now owns over 1000 domestic and foreign patents, and has led or participate in establishment and revision of over 120 industrial standards. Its HV and LV electric appliances and photovoltaic inverters won Germany Wed Dot Award. CHINT led development of critical manufacturing equipment PECVD, LPCVD, and MOCVD for China's first silicon based thin film photovoltaic cells, which has significantly improved semiconductor equipment manufacturing level in China.

The group has won a number of awards including China Industrial Award, National Quality Management Award, China Excellent Private Science & Technology Enterprise, China Top Ten Machinery Manufacturers with Core Competitiveness, China Top Ten Leading Private Enterprises with Independent Innovation Capabilities, China Contract-Fulfilling and Trustworthy Enterprise, National Advanced Private Enterprise for Employment and Social Security, and China Charity Award.

In the future, CHINT will march towards the targets of creating world famous brands and contributing to an industrial power. It will focus on building the Energy Internet and becoming a smart energy developer and operator. The group will make great efforts to implement three policies: globalization, M&A and integration, and smart manufacturing. Four platforms will be created, including scientific innovation and industrial incubation platform, online industrial and civil Internet of Things platform, online & offline supply chain interaction platform, and investment & financing and payment platform. Four industrial clusters will also be developed, including smart electrical system solution industrial cluster for smart grid, industrial automation information cluster for smart cities, clean energy, environment protection, and energy conservation industrial cluster for smart micro-grid, high-tech material information technology and high-end equipment industrial cluster for smart manufacturing, and Internet of Things IT and smart home industrial group for smart business.

Air Circuit Breaker



Built-in busbar temperature sensor, to control every aspect

-35°C/+70°C operating temperature range. Meets several applications requirements.



More detailed division of frame size, can fully cover various demands

With a frame size of 1600A, 2000A, 3200A, 4000A, it provides a more cost-effective choice.



With a USB port for better human-machine interaction

Connected with PC or mobile devices through the USB port, lets you manage functions such as data reading, parameter setting, on-line detection and failure recording.



Absolute adaptability, with steady and reliable operation in extreme conditions

-35°C/+70°operating temperature range. Meets several applications requirements.

Real-time temperature sensor

Continuous function monitoring
More accurate risk identification



NXA series air circuit breaker

Structural features of the circuit breaker

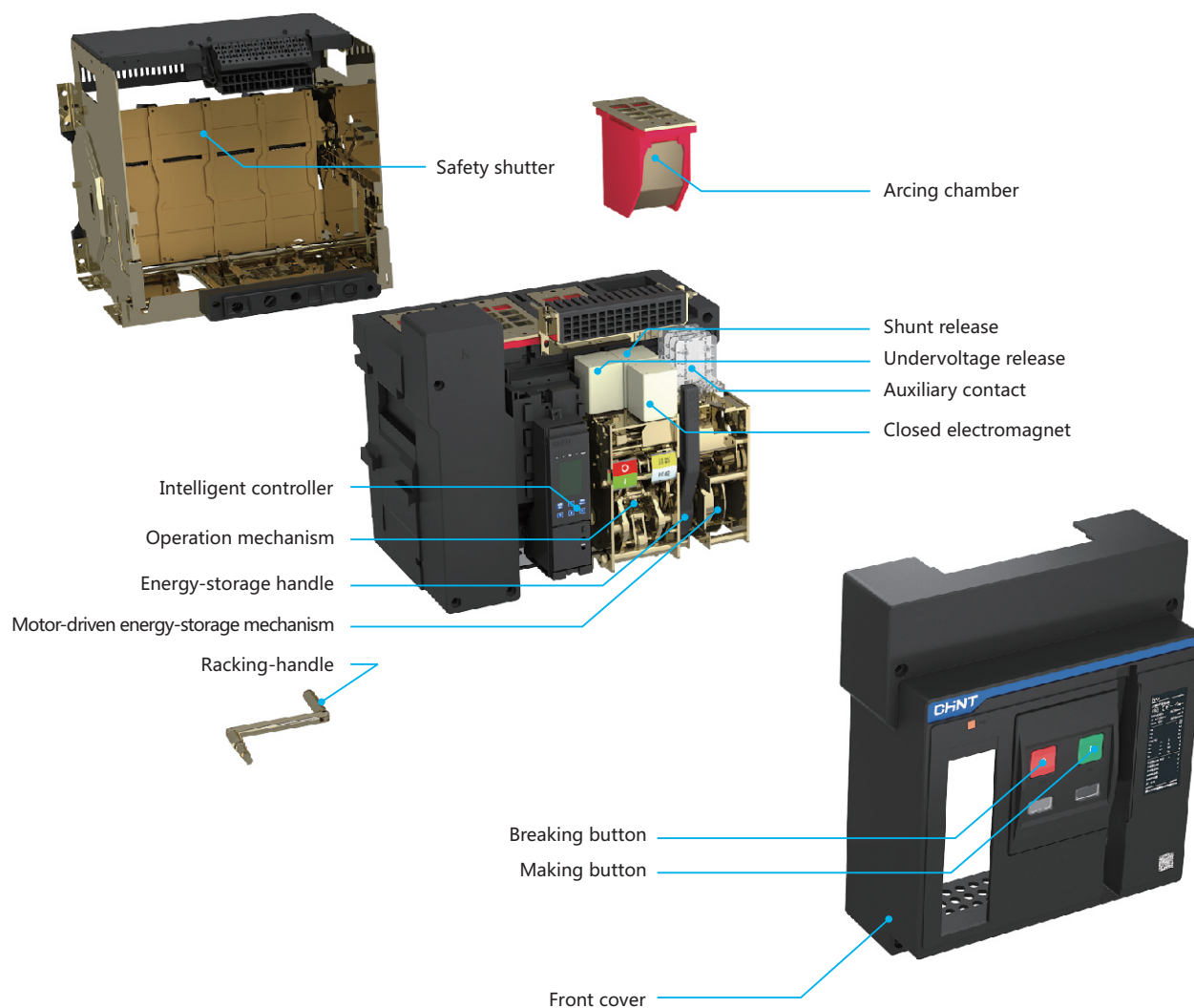

NXA series air circuit breaker

Circuit breaker description

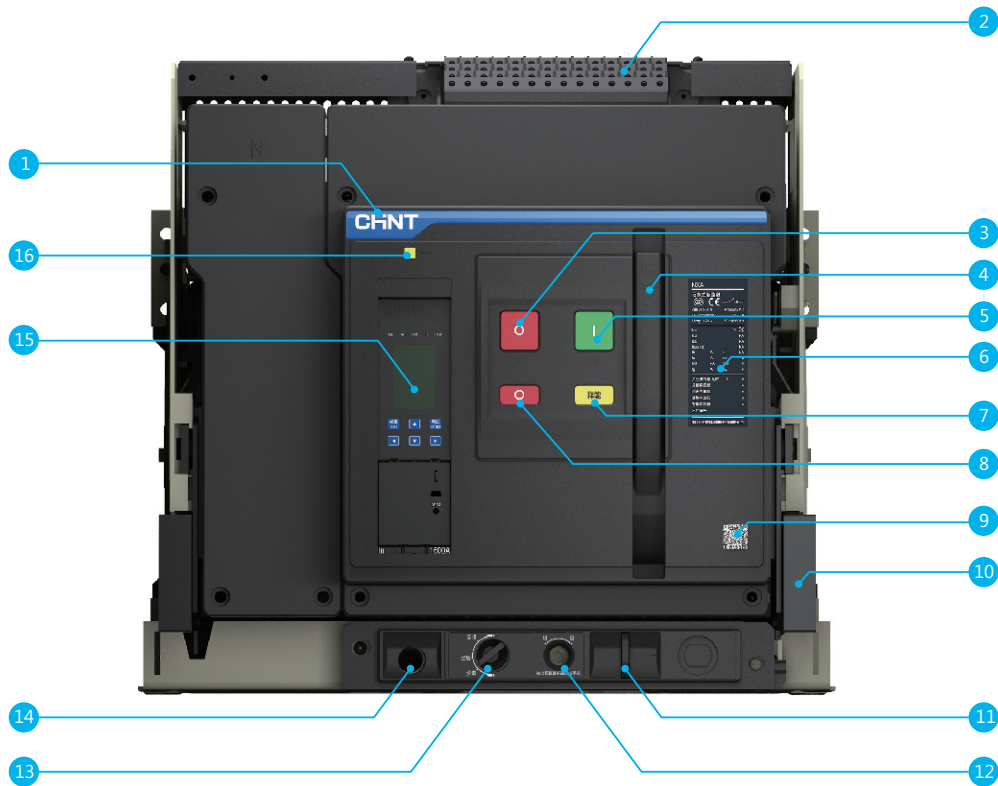

1 Trademark

2 Secondary wiring terminal

3 Breaking button

4 Energy-storage handle

5 Making button

6 Nameplate

7 Energy-storage/release indicator

8 Breaking/making indicator

9 QR code

10 Extraction draw plate (only applicable to draw-out type)

11 "Disconnected" position locking (only applicable to draw-out type)

12 Racking-handle entry (only applicable to draw-out type)

13 Position indication (only applicable to draw-out type)

14 Racking-handle storage (only applicable to draw-out type)

15 Intelligent controller

16 Fault-breaking indicator reset button

Overview

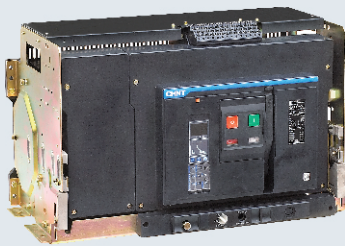

Circuit breaker

- Frame size (A): 1600, 2000, 3200, 4000
- Breaking capacity: N,S,H
- Rated operational voltage U_e (VAC): 380/400/415
- Number of poles: 3P, 4P
- Installation method: draw-out type, fixed type
- Wiring type: horizontal rear connection

Operation conditions and environment adaptability

- Operation temperature:
The electrical and mechanical characteristics are applicable to the ambient temperature of -5°C - $+40^{\circ}\text{C}$. NXA can also operate in the ambient temperature of -45°C - $+70^{\circ}\text{C}$ (M type, A type), -20°C - $+70^{\circ}\text{C}$ (P type, H type, CD-1), the derating factor is seen in P21-22.
- Storage conditions: apply to -45°C - 70°C
- NXA can resist the following electromagnetic interference
 - Overvoltage generated by electromagnetic interference
 - Overvoltage caused by environment interference or a power distributing system
 - Electrostatic discharge of radio waves (radio, intercom, radar and the like)
- The NXA circuit breaker has successfully passed the test for electromagnetic compatibility specified according to the following standards (EMC) IEC/EN 60947-2 Annex F
The test can guarantee no false tripping and no interference on tripping time
- Protection grade:
Front IP 20, other side IP 00

Intelligent controller

- M type (basic type)
Basic function: protective function L S I&G
- A type (current type)
 - Comprising all protective functions of M type
 - Current measurement and display
 - Unbalanced current protection
- P type (power type)
 - Basic function, protective function: L, S, I&G
 - Power measurement functions of current, voltage, power, busbar temperature etc.
 - LCD display
- H type (harmonic type)
 - Comprising all protection and measurement functions of P type
 - Harmonic measurement and analysis
 - Communication function

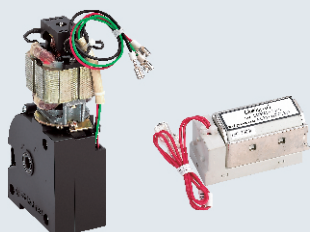
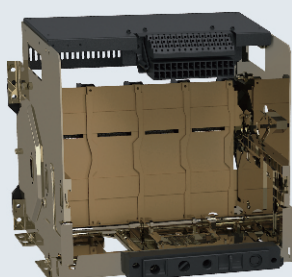
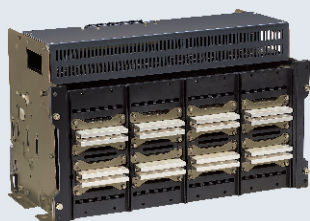

Connection

- Rear connection
Horizontal connection
- Optional accessories
Interphase barrier

Lock

- Padlocks of "Making" and "Breaking" push button
- Position padlock (for locking the circuit breaker at disconnected position)
- Chassis padlock
- Door interlock: the circuit breaker is arranged at the connected or test part so as to prohibit to open the door

Indication contact

- Standard contact
Making and breaking indication contacts
Fault tripping indication contact
Spring charged indication contact
- Optional accessories
Position indication contact

Remote operation

- Standard accessories
Electric operating mechanism
Closing electromagnet CC
Shunt release ST
- Optional accessories
Standard undervoltage release: UVT
Adjustable time-delay undervoltage release: UVTD

Secondary wiring terminal

- Optional accessories
Fast wiring control terminal, without screw installation

Source-changeover systems

- Mechanical interlock
2 normal and 1 replacement
2 incoming and 1 busbar
- Source-changeover controller (with adaptor)
2 normal and 1 replacement: mechanical interlock+2A type controller
2 incoming and 1 busbar: mechanical interlock+3A type controller

Product selection

NXA series air circuit breaker

Frame size	Rated current Breaking capacity	400	630	800	1000	1250	1600	2000	2500	3200	3600	4000
		1600A	N	■	■	■	■	■	■			
	H	■	■	■	■	■	■					
2000A	N		■	■	■	■	■	■				
	H		■	■	■	■	■	■				
3200A	N						■	■	■	■		
	H						■	■	■	■		
4000A	N									■	■	■
	H									■	■	■

Model definition and description

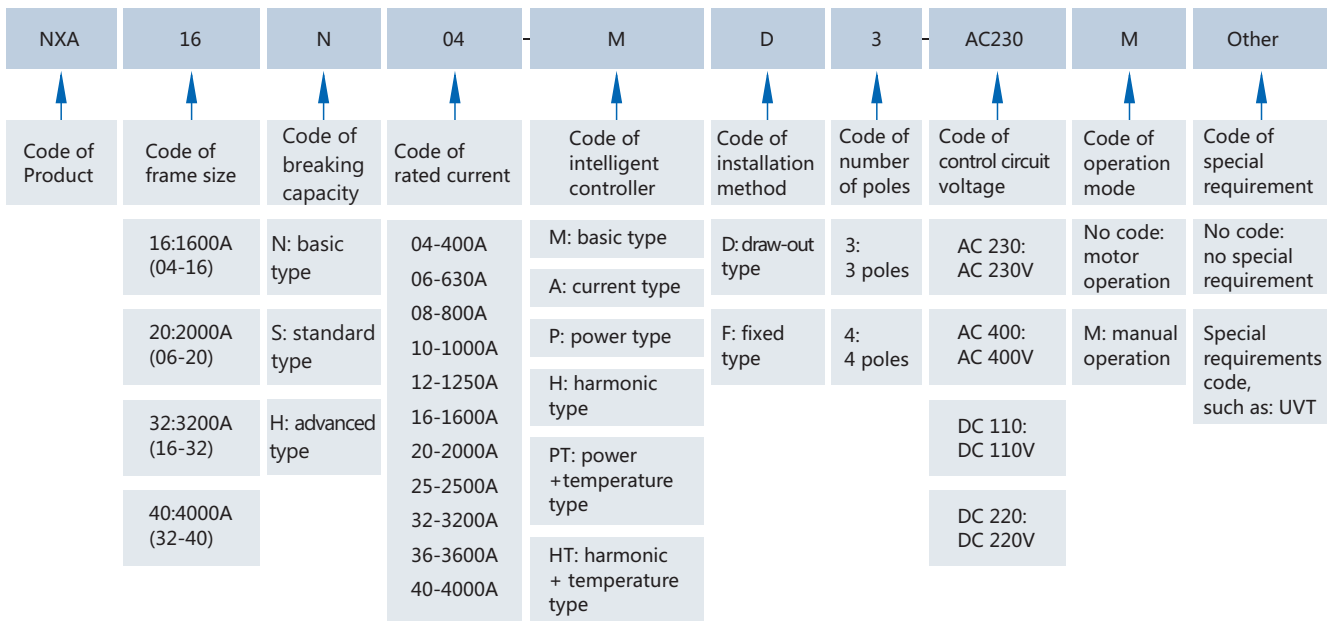

Note: ¹⁾ Intelligent controller PT/HT type. The basic functions are the same with P/H type. T refers to the internal temperature measurement function.

²⁾ Manual operation does not contain motor-driven mechanism, closing electromagnet and shunt release. Motor operation contains all standard accessories of remote operation.

³⁾ Auxiliary working voltage of the intelligent controller: corresponding power modules is required if DC220V or DC110V is selected.

⁴⁾ NXA16N10-AD3-AC230: frame size is 1600A, N type breaking capacity, rated current is 1000A, A type intelligent controller, draw-out type and 3 poles, control voltage is AC 230V motor operation.

Model definition and description-intelligent controller

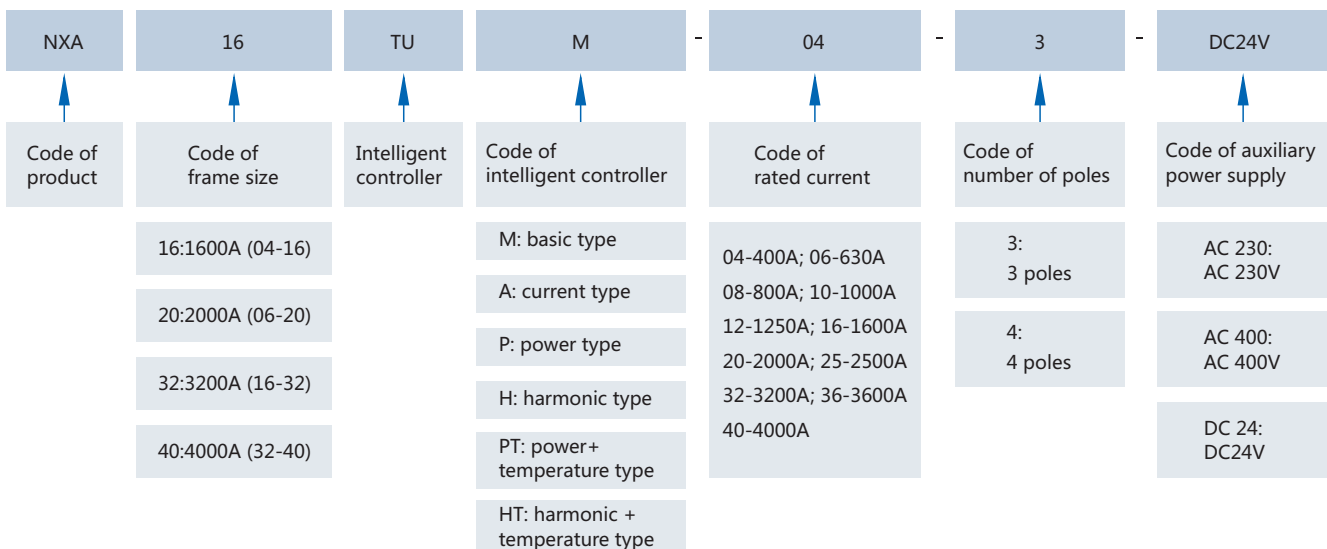

Model definition and description-accessories

NXA	16	-	CC	-	230VAC
Code of product	Frame size		Code of accessories		Code of rated voltage
	16:1600A		CC: Closed electromagnet		230VAC: AC230V
	20:2000A		ST: Shunt tripper		400VAC: AC400V
	32:3200A		UVT: Undervoltage tripper		110VDC: DC110V
	40:4000A		MO: Motor		220VDC: DC220V
	20/40:2000A-4000A				
	20/32:2000A-3200A				

Model definition and description-accessories

NXA	16	OF	C04
Code of product	Frame size	Code of accessories	Specification of accessories
	16:1600A	OF: Auxiliary contact	C04: Four groups of contacts
	20:2000A		C05: Five groups of contacts
	32:3200A		C06: Six groups of contacts
	40:4000A		N3: Three normally open and three normally closed
	20/40:2000A-4000A		N4: Four normally open and four normally closed
	20/32:2000A-3200A		N5: Five normally open and five normally closed
			1S1S: One lock and one key
		KL: Key lock	2S1S: Two locks and one key
		FCDP: Fixed type door frame	3S2S: Three locks and two keys
		DCDP: Draw-out type door frame	
		FD: Fixed type interphased partition	
		DD: Draw-out type interphased partition	
		CE-CD-CT: Position signal	
		ILK2: Mechanical interlocking two interlocking steel cables	

Functions and features



Technical parameters

Features

Number of poles	3/4	
Rated operational voltage Ue (V)	380/400/415	
Rated insulation voltage Ui (V)	1000	
Rated impulse withstand voltage Uimp (kV)	12	
Rated frequency Hz	50/60	
Flashover distance (mm)	0	
Applicable to isolation	IEC/EN 60947-2	Applicable
Pollution grade	IEC 60664-1	N:3

Frame size

Rated current (A)

Rated current of the fourth pole (A)

Type of the circuit breaker

Rated ultimate short circuit breaking capacity (kA rms) VAC 50/60Hz Icu 380/400/415V

Rated service short circuit breaking capacity (kA rms) VAC 50/60Hz Ics 380/400/415V

Utilization category

Rated short-time withstand current (kA rms) VAC 50/60Hz Icw 1s, 380/400/415V

Closed capacity kA peak) VAC 50/60Hz Icm 380/400/415V

Making current tripping protection function (MCR kA rms)

Breaking time (ms)

Closing time (ms)

Installation, connection and service life

Service life C/O cycle	Mechanical	Without maintenance
	Electrical	Without maintenance

Connection Horizontal

Size (width × depth × height) Fixed type 3P
4P

Draw-out type 3P
4P

Functions and features

	1600A						2000A						3200A				4000A		
	400	630	800	1000	1250	1600	630	800	1000	1250	1600	2000	1600	2000	2500	3200	3200	3600	4000
	400	630	800	1000	1250	1600	630	800	1000	1250	1600	2000	1600	2000	2500	3200	3200	3600	4000
	N	H					N	S	H				N	S	H		N	S	H
	50	55					80	65	80				80	80	100		80	85	100
	30	42					50	65	65				65	80	80		65	85	85
	B						B						B				B		
	30	42					50	65	65				65	80	80		65	85	85
	105	121					176	176	176				176	220	220		176	220	220
	10	16					16	16	16				26	26	26		26	26	26
	32						32						32				32		
	70						70						70				70		
	15000						15000						10000				10000		
	8000						8000						5000				3000		
	■						■						■				■		
	254×243.5×318.5						374×344×400						439×373.5×400				550×337.5×400		
	324×243.5×318.5						469×344×400						554×373.5×400				700×337.5×400		
	308×331.5×351						403×430×438.5						463×499.5×438.5				569×416×438.5		
	378×331.5×351						498×430×438.5						578×499.5×438.5				719×416×438.5		

Functions and features

Intelligent controller

M type intelligent controller (Basic type)

Protection

All the protective threshold and time delay are set by a dial switch

- Overload protection
 - True RMS long-time-delay protection
 - Thermal memory: heat accumulation before and after tripping
- Short circuit protection
 - Short-time delay (RMS) and instantaneous protection
 - Optional time-delay in four steps constant time-lag
- Earth fault protection
 - Optional time-delay in four steps constant time-lag
- Neutral line overcurrent protection (4P)
 - the neutral protection threshold can be adjusted to 50%, 100% and OFF
- Test function
 - Simulating $6I_n$ test current for test tripping
- Tripping record function

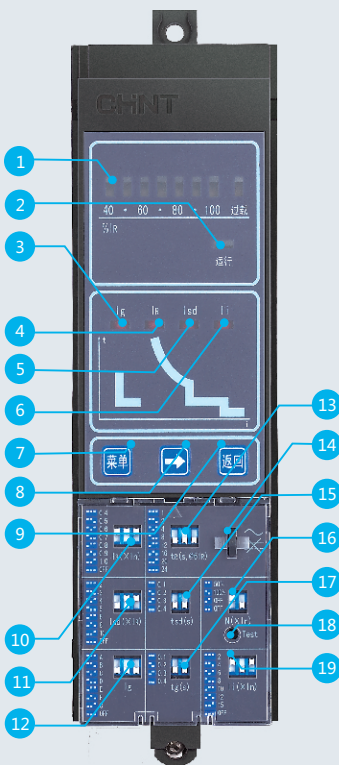

1. Current indicator:
for indication of % loading during running condition
2. Running indicator: flickering normally
3. I_g indicator for earth fault indication
4. I_x indicator for overload long-time-delay tripping
5. I_{sd} indicator for short circuit short-time-delay tripping
6. I_i indicator for short circuit tripping
7. Menu button for inquiring the dial position and fault record
8. Rightward button: turn to the next state when inquiring the dial position
9. Return button: back to the previous level or resetting
10. Overload long-time-delay current setting
11. Short circuit short-time-delay current setting
12. Earth fault current setting
13. Overload long-time-delay time setting
14. Transparent cover lockhole
15. Short circuit short-time-delay time setting
16. Neutral line protection setting
17. Earth fault time-delay setting
18. Test button for simulating $6I_n$ current
19. Short circuit instantaneous current setting

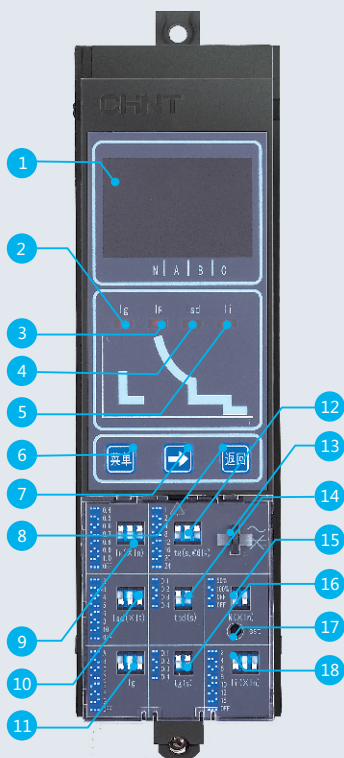

1. Display window: display the current value, the setting parameter, the fault current, the tripping time
2. Ig indicator for earth fault indication
3. IR indicator for overload long-time-delay tripping
4. Isd indicator for short circuit short-time-delay tripping
5. Ii indicator for short circuit tripping
6. Menu button for inquiring the dial position and fault record
7. Rightward button: turn to the next state when inquiring the dial position
8. Return button: back to the previous level or resetting
9. Overload long-time-delay current setting
10. Short circuit short-time-delay current setting
11. Earth fault current setting
12. Overload long-time-delay time setting
13. Transparent cover lockhole
14. Short circuit short-time-delay time setting
15. Neutral line protection setting
16. Earth fault time-delay setting
17. Test button for simulating 6IR current
18. Short circuit instantaneous current setting

A type intelligent controller (Current type)

Protection

Setting all the protective threshold values and a dial switch for time delay. The setting values can be displayed on LCD display window.

- Overload protection
 - True RMS long-time-delay protection
 - Thermal memory: heat accumulation before and after tripping
- Short circuit protection
 - Short-time delay (RMS) and instantaneous protection
 - Optional four steps time-delay setting
- Earth fault protection
 - Optional four steps time-delay setting
- Neutral line overcurrent protection (4P)
 - The neutral protective threshold can be adjusted to 50%, 100% and OFF
- Unbalanced current protection
 - Protecting phase failure or three phase unbalance
- Test function
 - Simulating 6IR test current for test tripping
- Tripping record function
- Ampere meter
 - Measure the real and effective value (RMS) of current with the precision of 2% for 40% to 150% in setting

Functions and features

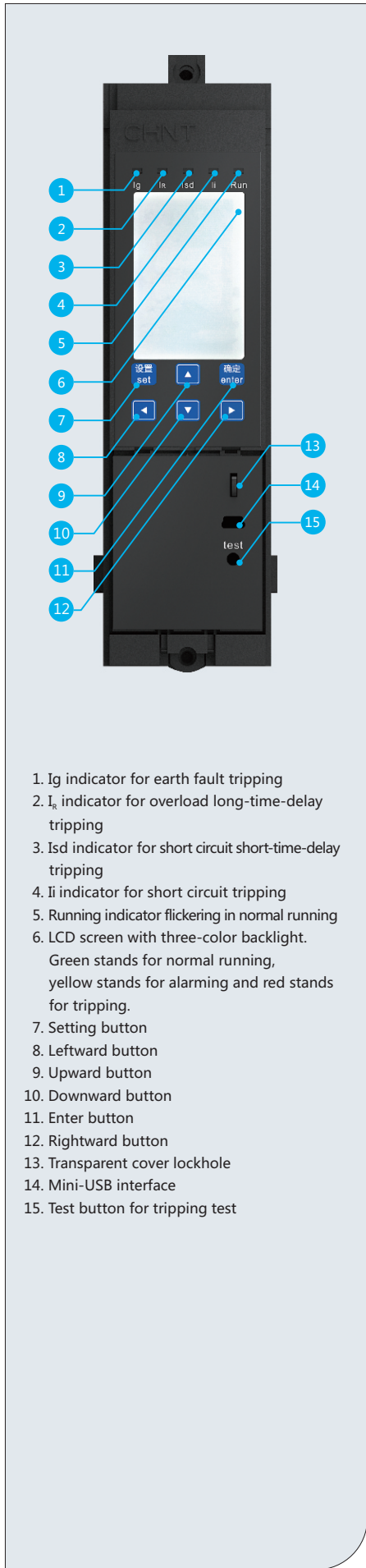

1. Ig indicator for earth fault tripping
2. I_r indicator for overload long-time-delay tripping
3. Isd indicator for short circuit short-time-delay tripping
4. Ii indicator for short circuit tripping
5. Running indicator flickering in normal running
6. LCD screen with three-color backlight.
Green stands for normal running, yellow stands for alarming and red stands for tripping.
7. Setting button
8. Leftward button
9. Upward button
10. Downward button
11. Enter button
12. Rightward button
13. Transparent cover lockhole
14. Mini-USB interface
15. Test button for tripping test

P type intelligent controller (Power type)

Protection

Setting all protective threshold values and time-delay

- Protection functions of all A type control units are included
- Earth current protection function (Optional)
External transformer and protection module are configured
- Advanced protection function
 - Unbalanced voltage protection
 - Overvoltage and undervoltage protection
 - Overfrequency and underfrequency protection
 - Phase sequence protection
 - Reverse power protection function
 - Required value protection function

The required value of the real and effective value of each current is calculated within a measurement window. When the required value is off limit, the protection action is carried out. The setting of a sliding time window is in the menu of "setting of a measurement meter".

- A-phase maximal required current value,
- B-phase maximal required current value,
- C-phase maximal required current value,
- N-phase maximal required current value are respectively set for each circumstance of the required value protection without being affected by the setting of the neutral line protection.

- Extended function
 - Self-diagnosis by the intelligent controller
 - Operation times/fault tripping/alarming/deflection recording function provides the latest eight times of recording
 - Main contact abrasion display function for evaluating the contact abrasion degree according to mechanical life, electrical services and breaking capacities of different frames.
 - Internal clock function
 - A Mini-USB interface is connected with a PC to achieve the functions of protection setting, fault record downloading, whole power quantity detection and parameter reading of a circuit breaker.
 - "test" push button
- Electric energy meter
 - Current measurement
 - Voltage measurement
 - Frequency measurement
 - Required value measurement
 - Power (active power, reactive power and apparent) measurement
 - Electric energy (active power, reactive power and apparent) measurement
 - Power factor measurement
- Busbar temperature measurement (Optional)
The temperature of the busbar is measured by a temperature transformer in the busbar, and can be display on a LCD screen in real time. Customers can set the temperature threshold value and set the alarm.
- LCD three-color backlight
Green stands for normal running, yellow stands for alarming and red stands for tripping.

H type intelligent controller (Harmonic wave type)

Protection

Setting all protective threshold values and a button for time-delay

Besides the protective extended function of all P type control units, H type control unit also comprises:

- Load monitoring function
- Zone selective interlock (ZSI)
- Communication function
 - Modbus-RTU communication protocol
- Input/output function
 - 2DI, 2DO or 4DO
 - DI signal: AC230V (Standard configuration, and others can be selected); AC400V; DC110V; DC220V; DC24V
 - DO needs to be configured with a power supply module (24VDC output) and a relay module.
- Harmonic analysis function
 - Measurement of the fundamental wave current, the fundamental wave line voltage, the fundamental wave phase voltage, the fundamental wave power and each 3-31 odd harmonic wave current percentage (HRIh), the harmonic voltage percentage (HRUh), the total harmonic wave current distortion rate (THDi, thdi) and the total harmonic wave voltage distortion rate (THDu, thdu).
 - The harmonic wave percentage(HR) refers to the ratio of root-mean-square value of the Nth harmonic wave component contained in periodic alternative current quantity to the root-mean-square value of the fundamental wave component, and is expressed in percentage.

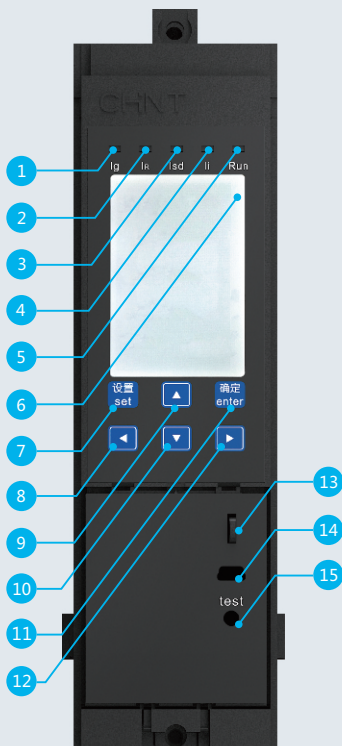

1. Ig indicator for earth fault tripping
2. IR indicator for overload long-time-delay tripping
3. Isd indicator for short circuit short-time-delay tripping
4. Ii indicator for short circuit tripping
5. Running indicator flickering in normal running
6. LCD screen with three-color backlight.
Green stands for normal running, yellow stands for alarming and red stands for tripping.
7. Setting button
8. Leftward button
9. Upward button
10. Downward button
11. Enter button
12. Rightward button
13. Transparent cover lockhole
14. Mini-USB interface
15. Test button for tripping test

Functions and features

Protection features

The protection features of the intelligent controller comprise inverse time characteristic and constant time characteristic. When the fault current exceeds the set value of the inverse time limit, the controller performs constant time protection. The inverse time limit corresponds to the feature curve I^2t .

Overload long-time-delay protection feature

Overload long-time-delay protection action threshold value
 $<1.05I_R$: $>2h$, no action
 $>1.3I_R$: $<1h$, action

Ir current setting value range: 0.4In, 0.5 In, 0.6 In, 0.7 In, 0.8 In, 0.9 In, 1.0 In+OFF
 Inverse time limit action feature: I^2t , wherein $t=(6/N)^2 \times t_r$

Setting Multiple of Current	Action Time							
1.5I _e	16	32	64	128	192	256	320	384
2I _e	9	18	36	72	108	144	180	216
6I _e	1	2	4	8	12	16	20	24

Note: N --- the multiple I/IR obtained by dividing failure current by set current
 t --- time delay action of the failure action
 t_r --- long-time-delay set value
 Allowed error of the action time $\pm 15\%$

Short circuit short-time-delay protection feature

Short circuit short-time-delay protection action threshold value
 $<0.85I_{sd}$: no action
 $>1.15I_{sd}$: action
 I_{sd} current set value range: 2I_R, 3I_R, 4 I_R, 5I_R, 6I_R, 8I_R, 10I_R +OFF (MAX 50kA)

Current	Action time		Remark
$I_{sd} < I \leq 10I_e$	Inverse time limit	Action feature $I^2t = (10I_e)^2 \times tsd$	P, H
		Setting time s 0.1, 0.2, 0.3, 0.4	
$I \geq 1.1I_{sd}$	Constant time limit	Setting time s 0.1, 0.2, 0.3, 0.4	M, A, P, H
		Minimum s 0.06, 0.16, 0.255, 0.34	
	Maximum s 0.14, 0.24, 0.345, 0.46		
	Return time	0.05, 0.14, 0.25, 0.33	

Note: I_{sd}---short-time-delay current set value
 I--- failure current value
 I_R--- long-time-delay set value
 t--- failure action time-delay time
 tsd---short-time-delay inverse time limit set value
 Permissible error of action time $\pm 15\%$

Short circuit instantaneous protection features

Short circuit instantaneous protection action threshold value

<0.85I_i: no action

>1.15I_i: action

The current setting value of instantaneous action: 2I_n, 4I_n, 6I_n, 8I_n, 10I_n, 12I_n, 15I_n+OFF(NXA40 MAX50kA)

Note: action time ≤ 50ms

Earth fault protection action features

Earth fault protection action threshold value

<0.9I_g: no action

>1.1I_g: action

Current setting value	A	B	C	D	E	F	G	OFF
NXA16, 20	0.2I _n	0.3I _n	0.4I _n	0.5I _n	0.6I _n	0.8I _n	I _n	
NXA32, 40, 63	500A	640A	800A	960A	1040A	1120A	1200A	
tg(s)	Inverse time limit	Action features						

$$t = \frac{(I_g)^2}{I^2} \times t_g$$

Constant time limit	Setting time (s)	0.1	0.2	0.3	0.4
	Minimum (s)	0.06	0.16	0.255	0.34
	Maximal (s)	0.14	0.24	0.345	0.46
	Return time	0.05	0.14	0.25	0.33

Note: I_g --- earth fault protection setting value. When I_n ≥ 1250A, I_g = 1200A. When I_n < 1250A, I_g = I_n. When I_n ≥ 1250A, I_g MAX = 1200A

I --- failure current value

t --- failure action time-delay time

t_g --- earthing inverse time limit set value

The permissible error of the inverse time limit action time: ±15%

Functions and features

Measurement precision of the intelligent controller

Current measurement	
Measurement range	Ia, Ib, Ic and IN are not less than 15In (rated current of the circuit breaker)
Measurement precision	Below 0.1In: the measurement is inaccurate
	0.1In-0.4In: the accuracy will be changed linearly from 5% to 2%
	0.4In-1.5In: the accuracy is 2%
	>1.5In: the accuracy will be changed linearly from 2% to 15%
The measurement accuracy of the earthing current is 10%	
Voltage measurement	
Measurement range	Line voltage: 0V~1300V Phase voltage: 0V~900V
Measurement precision	Error: ±1%
Frequency	
Measurement range	40HZ~70HZ
Measurement precision	Error: ± 0.1HZ
Power	
Measurement mode	The effective value mode
Measurement content	3P type: total active power, total reactive power and total apparent power
	4P type: phase splitting active power, phase splitting reactive power, phase splitting apparent power, total active power, total reactive power, total apparent power
Measurement power	Active power: -32768KW~ + 32767KW
	Reactive power: -32768Kvar~ + 32767Kvar
	Apparent power: 0KVA~65535KVA
	Error: ±2.5%
Power factor	
Measurement content	3P type: total power factor
	4P type: phase splitting power factor
Measurement range	-1.00~+1.00
Electric energy	
Measurement content	Input reactive electric energy EQin, output reactive electric energy EQout
	Input active electric energy EPin, output active electric energy EPout
	Total active electric energy EPTotal, total reactive electric energy EQtotal, total apparent electric energy ESTotal
Measurement range	Active electric energy: -32768KWh~ + 32767KWh
	Reactive electric energy: -32768Kvarh~ + 32767Kvarh
	Apparent electric energy: 0~65535KVAh
Measurement precision	Error ±2.5%
Harmonic wave measurement	
Fundamental wave measurement	Current: Ia, Ib, Ic
	Voltage: Uab, Ubc, Uca
Total harmonic wave distortion THDu and thdu	THD: the total distortion rate of the harmonic wave relatively to the fundamental wave
	Thd: the total distortion rate of the harmonic wave relatively to the effective value
Amplitude wave spectrum of harmonic wave	The controller can display FFT amplitude of odd harmonic wave from 3 to 31in percentage
Measurement precision of control unit	±2%

Functions and features

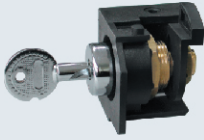

Accessories: locks

Pushbutton lock

The pushbutton lock is to lock the circuit breaker by a transparent cover blocks so as to prevent the breaking button and the making button of the circuit breaker from misoperation and guarantee the reliable running of the circuit breaker.

Body lock

- A key lock includes four types. The latter two are applied to 2 input and 1 connect power distribution system:
 - Random lock
 - One lock and one key
 - Two locks and one key
 - Three locks and two keys

Safety shutters padlock

- The padlock is prepared by users.
 - when a circuit breaker body is at the disconnected or test part, the safety shutters automatically block access to the disconnecting contact cluster.

"Disconnected" position padlock

After the chassis and body are locked at "Disconnected" position by a padlock, the racking-handle cannot be inserted into racking-handle entry, and then the position of the body cannot be changed.

Door interlock

- Circuit breaker state door interlock
 - A cabinet door is prohibited to be opened when the circuit breaker is closed.
 - The cabinet door is allowed to be opened when the circuit breaker is disconnected.
- Circuit breaker position door interlock
 - The cabinet door is prohibited to be opened when the circuit breaker is at the connected and test part. The cabinet door is allowed to be opened when the circuit breaker is at the disconnected position.

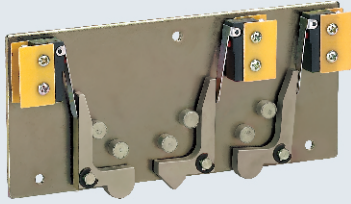
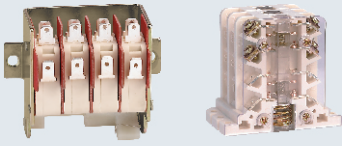

Accessories: indication contacts

ON/OFF indication contacts

Standard configuration	4CO	
Breaking capacity	Current (A) / Voltage (V)	
Utilization category	VAC(AC-15)	1.3/240, 0.75/415
	VDC(DC-13)	0.55/220, 0.27/110

"Connected", "disconnected" and "test" position indication contact

Standard configuration	1CO/3	
Breaking capacity	Current (A) / Voltage (V)	
Utilization category	VAC(AC-15)	1.3/240, 0.75/415
	VDC(DC-13)	0.55/220, 0.27/110

Alarming contact

Standard configuration	1CO	
Breaking capacity	Current (A) / Voltage (V)	
Utilization category	VAC(AC-15)	1.3/240, 0.75/415
	VDC(DC-13)	0.55/220, 0.27/110

Spring charging indication contact

Standard configuration	1NO	
Breaking capacity	Current (A)/ Voltage (V)	
Utilization category	VAC(AC-15)	1.3/240, 0.75/415
	VDC(DC-13)	0.55/220, 0.27/110

Note: ¹ CO refers to a switch contact, and a one-normally-open and one-normally-closed contact is matched with a common terminal.

² NO refers to a normally open contact. NC refers to a normally closed contact.

Functions and features

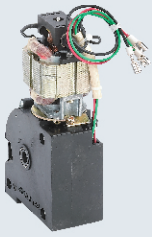

1600A frame MO

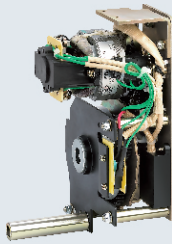

2000~4000A frame MO

● Motor-driven mechanism (MO) (Standard configuration)

When a circuit breaker is switched on, an motor operation mechanism stores energy automatically, so that when the circuit breaker is tripped, the device can switch on instantly. An energy-storage handle as spare when no auxiliary power supply is provided.

Characteristics		
Power supply	VAC 50/60HZ	220/230/240, 380/400/415
	VDC	110, 220
Operation threshold		0.85-1.1Us
Frame size: power loss (VA or W)		16: 75W; 20: 85W; 32: 110W; 40: 10W
Motor overcurrent		≤1min
Charging time		≤7s
Operation frequency		≤2times/min

● Voltage coils (CC &ST) (Standard configuration)

● Closing coil (CC)

The CC closing coil remotely closes the circuit breaker if the spring mechanism is charged.

● Shunt release (ST)

The ST release instantaneously opens the circuit breaker when energised.

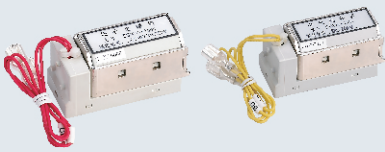

1600A frame CC&ST

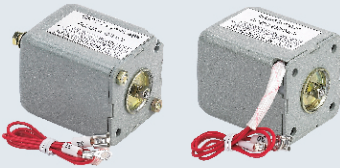

2000~4000A frame CC&ST

Characteristics		CC	ST
Power supply	VAC 50/60HZ	220/230/240 380/400/415	220/230/240 380/400/415
	VDC	220, 110	220, 110
Operational voltage		0.85-1.1Us	0.7-1.1Us
Frame size: power loss (VA or W)	AC	16: 400VA; 20~40: 400VA	16: 400VA; 20~40: 400VA
	DC	16: 380W; 20~40: 130W	16: 380W; 20~40: 130W
Circuit breaker response time at Un		40ms-60ms	30ms-50ms

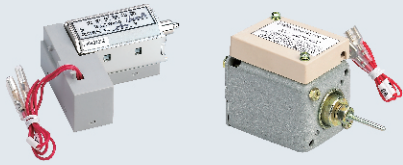

1600A frame UVT

2000~4000A frame UVT



2000~4000A frame UVTD

- Undervoltage release (UVT)

When the power supply voltage drops to be a value between 35%-70%, the release coil causes the circuit breaker to trip instantly. If there is no supply on the release, it is impossible to close the circuit breaker, either manually or electrically. Circuit breaker closing is enabled again when the supply voltage of the release returns to 85% of its rated value.

Characteristics			
Power supply	VAC 50/60HZ	220/230/240, 380/400/415	
	VDC	-	
Operation threshold	Open	0.35-0.7Ue	0.35-0.7Ue
	Closed	0.85Ue	0.85-1.1Ue
Frame size: power loss (W)			16: 220W/15W; 20~40: 220W/13W

Note: actuation/maintaining.

- UVT delay unit (UVTD)

To eliminate the false tripping caused by short-time voltage drop, UVT action time delay is required. The function is realized by additionally increasing a time delay unit for UVT.

Characteristics		
Power supply	VAC 50/60HZ	
Operation threshold	Open	0.35-0.7Ue
	Closed	0.85Ue
Frame size: power loss (VA)	16: 20VA; 20~40: 48VA	
Adjustable time	16: 0.5s, 1s, 2s, 3s, 5s; 20~40: 1s, 3s, 5s	

Functions and features

Capacity derating and power loss

Temperature capacity derating table of the fixed type circuit breaker

1600A frame

Ambient temperature	400A		630A		800A		1000A		1250A		1600A	
Connection mode	Horizontal	Vertical	Horizontal	Vertical	Horizontal	Vertical	Horizontal	Vertical	Horizontal	Vertical	Horizontal	Vertical
40°	-	-	-	-	-	-	-	-	-	-	-	-
45°	-	-	-	-	-	-	-	-	-	-	-	-
50°	-	-	-	-	-	-	-	-	-	-	1550	1600
55°	-	-	-	-	-	-	-	-	1150	1200	1500	1550
60°	-	-	550	580	-	-	-	-	1050	1100	1450	1500

2000A frame

Ambient temperature	630A		800A		1000A		1250A		1600A		2000A	
Connection mode	Horizontal	Vertical	Horizontal	Vertical	Horizontal	Vertical	Horizontal	Vertical	Horizontal	Vertical	Horizontal	Vertical
40°	-	-	-	-	-	-	-	-	-	-	-	-
45°	-	-	-	-	900	-	-	-	1550	-	1900	-
50°	-	-	-	-	800	900	-	-	1500	1550	1850	1900
55°	-	-	700	800	700	800	-	-	1400	1450	1800	1800
60°	-	-	650	700	650	700	-	-	1300	1350	1700	1700

3200A frame

Ambient temperature	1600A		2000A		2500A		3200A	
Connection mode	Horizontal	Vertical	Horizontal	Vertical	Horizontal	Vertical	Horizontal	Vertical
40°	-	-	-	-	-	-	-	-
45°	-	-	-	-	-	-	-	-
50°	-	-	-	-	-	-	3100	-
55°	-	-	-	-	2450	-	3000	3050
60°	-	-	-	-	2350	2400	2900	2950

4000A frame

Ambient temperature	3200A		3600A		4000A	
Connection mode	Horizontal	Vertical	Horizontal	Vertical	Horizontal	Vertical
40°	-	-	-	-	-	-
45°	3100	-	-	-	3800	3850
50°	3000	-	-	-	3600	3650
55°	3000	3050	3400	3450	3400	3450
60°	2900	2900	3200	3250	3200	3250

Note: "-" refers to no capacity derating.

Temperature capacity derating table of the draw-out type circuit breaker

1600A frame

Ambient temperature	400A		630A		800A		1000A		1250A		1600A	
Connection mode	Horizontal	Vertical	Horizontal	Vertical	Horizontal	Vertical	Horizontal	Vertical	Horizontal	Vertical	Horizontal	Vertical
40°	-	-	-	-	-	-	-	-	-	-	-	-
45°	-	-	-	-	-	-	-	-	-	-	1550	-
50°	-	-	-	-	-	-	-	-	1150	1200	1500	1550
55°	-	-	550	580	-	-	-	-	1050	1100	1450	1500
60°	-	-	500	530	-	-	950	-	950	1000	1400	1450

2000A frame

Ambient temperature	630A		800A		1000A		1250A		1600A		2000A	
Connection mode	Horizontal	Vertical	Horizontal	Vertical	Horizontal	Vertical	Horizontal	Vertical	Horizontal	Vertical	Horizontal	Vertical
40°	-	-	-	-	-	-	-	-	-	-	-	-
45°	-	-	-	-	900	-	-	-	1500	-	1850	1900
50°	-	-	-	-	800	900	-	-	1400	1500	1750	1850
55°	-	-	700	-	700	800	-	-	1300	1400	1650	1750
60°	600	-	600	700	600	700	1200	-	1200	1300	1550	1650

3200A frame

Ambient temperature	1600A		2000A		2500A		3200A	
Connection mode	Horizontal	Vertical	Horizontal	Vertical	Horizontal	Vertical	Horizontal	Vertical
40°	-	-	-	-	-	-	-	-
45°	-	-	-	-	2450	-	3100	-
50°	-	-	-	-	2400	2450	3000	3100
55°	-	-	-	-	2350	2400	2900	3000
60°	-	-	-	-	2300	2350	2800	2900

4000A frame

Ambient temperature	3200A		3600A		4000A	
Connection mode	Horizontal	Vertical	Horizontal	Vertical	Horizontal	Vertical
40°	-	-	-	-	-	-
45°	3100	-	-	-	3800	3850
50°	3000	3100	-	-	3600	3650
55°	2900	3000	3400	3450	3400	3450
60°	2800	2900	3200	3250	3200	3250

Functions and features

Altitude capacity derating factor

Altitude height (m)		2000	3000	4000	5000
Rated impulse withstand voltage (kV)	Uimp	12	10	8.57	7.5
Average insulation grade (V)	Ui	1000	833	714	625
Maximal operational voltage (V) 50/60Hz	Ue	415	415	415	415
Average heat operational current(40)°C		1.0	0.97	0.93	0.89

Power loss and input and output resistance

Power loss is the power loss of each pole measured at In, 50/60Hz. The input/output resistance is the DC resistance value of each pole at the cold state.

Frame size	Rated current (A)	Draw-out type		Fixed type (W)	
		Power loss (W)	Input/output resistance (μohm)	Power loss (W)	Input/output resistance (μohm)
1600A	400	25.6	63.6	13.0	32.4
	630	63.6	63.6	32.4	32.4
	800	83.3	51.6	45.5	28.2
	1000	130.1	51.6	71.1	28.2
	1250	203.4	51.6	111.1	28.2
	1600	404.7	34.2	213.0	18.0
2000A	630	64.9	49.2	29.3	22.2
	800	104.7	49.2	47.3	22.2
	1000	163.6	49.2	73.8	22.2
	1250	199.56	38.4	99.2	19.1
	1600	326.95	38.4	162.5	19.1
	2000	431.0	32.4	226.7	17.0
3200A	1600	233.2	16.6	110.2	7.8
	2000	364.3	16.6	172.1	7.8
	2500	569.3	16.6	269.0	7.8
	3200	878.6	15.6	378.5	6.8
4000A	3200	625.3	14.1	344.4	7.8
	3600	992.6	17.7	392.3	7.0
	4000	1225.44	17.7	484.3	7.0

Dimension of busbar

Bolt configuration

Type of bolt	Application	Fastening busbar
16: M10	Fastening busbar	(49~59)N·m
20~63: M12	Preferred even twisting moment	(86~103)N·m

Hole size and installation twisting moment of busbar

Drilling Φ (mm)	Diameter of bolt	Fastening twisting moment
16: Φ 11	M10	(49~59)N·m
20~63: Φ 13	M12	(86~103)N·m

Connection busbar specification reference under different temperature

Maximum permissible temperature of busbar: 100°C

The material of busbar is bare copper

Frame size	Rated current (A)	Ambient temperature(-5~40)°C				Ambient temperature 50°C				Ambient temperature 60°C			
		5mm thick busbar		10mm thick busbar		5mm thick busbar		10mm thick busbar		5mm thick busbar		10mm thick busbar	
		Number of pieces	Specification	Number of pieces	Specification	Number of pieces	Specification	Number of pieces	Specification	Number of pieces	Specification	Number of pieces	Specification
1600A	400	2	30*5	1	30*10	2	35*5	1	35*10	2	40*5	1	40*10
	630	2	40*5	1	40*10	2	45*5	1	45*10	2	50*5	1	50*10
	800	2	50*5	1	50*10	2	55*5	1	55*10	2	60*5	1	60*10
	1000	2	60*5	1	60*10	2	65*5	1	65*10	2	70*5	1	70*10
	1250	2	80*5	1	80*10	2	85*5	1	85*10	2	90*5	1	90*10
	1600	2	100*5	1	100*10	2	105*5	1	105*10	2	110*5	1	110*10
2000A	630	2	40*5	1	40*10	2	45*5	1	45*10	2	50*5	1	50*10
	800	2	50*5	1	50*10	2	55*5	1	55*10	2	60*5	1	60*10
	1000	2	60*5	1	60*10	2	65*5	1	65*10	2	70*5	1	70*10
	1250	2	80*5	1	80*10	2	85*5	1	85*10	2	90*5	1	90*10
	1600	2	100*5	1	100*10	2	105*5	1	105*10	2	110*5	1	110*10
	2000	3	100*5	2	75*10	3	105*5	2	80*10	3	110*5	2	90*10
3200A	1600	2	100*5	1	100*10	2	105*5	1	105*10	2	110*5	1	110*10
	2000	3	100*5	2	75*10	3	105*5	2	80*10	3	110*5	2	90*10
	2500	4	100*5	2	100*10	4	105*5	2	105*10	4	110*5	2	110*10
	3200	8	100*5	4	100*10	8	105*5	4	105*10	8	110*5	4	110*10
4000A	3200	8	100*5	4	100*10	8	105*5	4	105*10	8	110*5	4	110*10
	3600	9	100*5	4	110*10	9	105*5	4	120*10	9	110*5	4	125*10
	4000	10	100*5	5	100*10	10	105*5	5	105*10	10	110*5	5	110*10

Note:

- When a copper bar selected by users is not matched with a wiring terminal of the circuit breaker, extended busbar is required to be designed to transfer, and is designed by the users of their own. The cross section of the extended busbar cannot be less than the requirement in the table above. The interval among the extended busbar is not less than the interval among wiring terminals of the circuit breaker.
- After the busbar recommended in the table above is installed, the electric clearance between adjacent phases of the circuit breaker is not less than 18mm.
- Electrical elements are used for three-phase rectification and high-frequency inversion, such as a high-frequency induction heating furnace (medium-frequency furnace steelmaking equipment), a solid high-frequency welding machine (such as an embedded arc electric welding machine), vacuum heating smelting equipment (such as a monocrystalline silicon growth furnace), in load equipment by controlled silicon. When a circuit breaker is selected, the influence on the circuit breaker by higher order harmonic component generated by controlled silicon is required to be considered besides the influences by the environment temperature and altitude height. At the same time, capacity derating is required, and the capacity coefficient (0.5-0.8) is recommended.
- The electric clearance of fastening bolts of upper and lower busbar needs to be not less than 20mm after the installation of the busbar by users.
- After the installation of the circuit breaker, the safety clearance among electrified bodies with different electric potential and between the electrified bodies and the ground are not less than 18mm.

Installation and wiring

Dimensions and installation

1600A fixed type

Front view

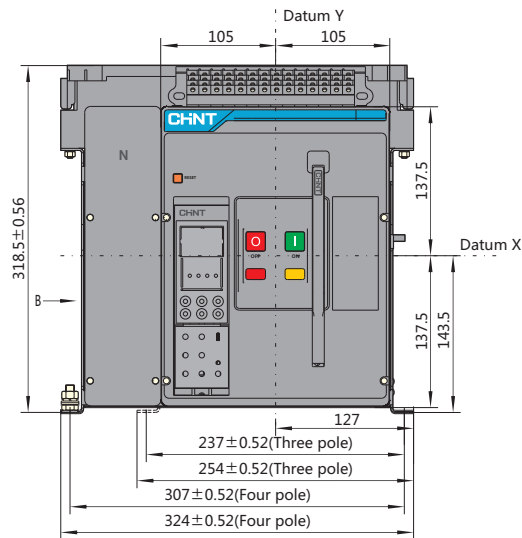

Side view

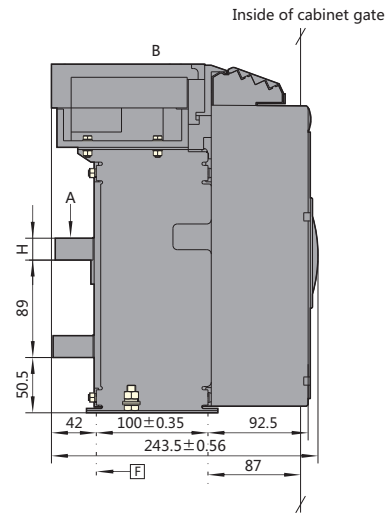

Hole size

Hole size of the base

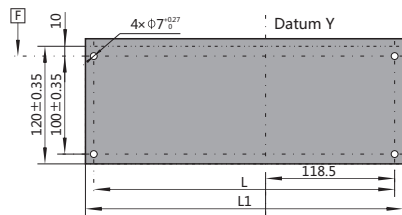

Schematic diagram of the overall size of the bottom surface and the installation hole pitch

H	L	L1	Remark
5	237 ± 0.46	254 ± 0.46	In=400A~630A Fixed type, three pole
8	237 ± 0.46	254 ± 0.46	In=800A~1250A Fixed type, three pole
20	237 ± 0.46	254 ± 0.46	In=1600A Fixed type, three pole
5	307 ± 0.52	324 ± 0.52	In=400A~630A Fixed type, four pole
8	307 ± 0.52	324 ± 0.52	In=800A~1250A Fixed type, four pole
20	307 ± 0.52	324 ± 0.52	In=1600A Fixed type, four pole

Hole size of a panel

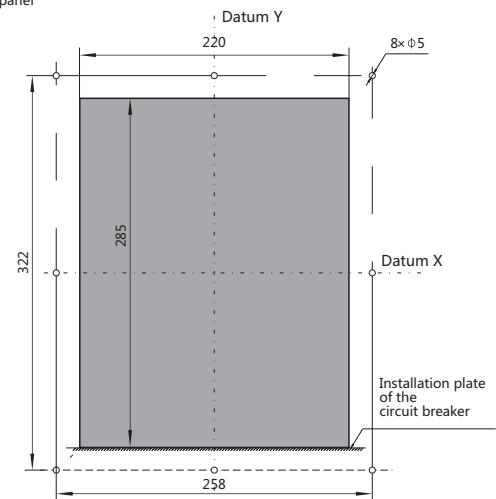

Hole size of the panel of the fixed type circuit breaker

Horizontal connection

Side view

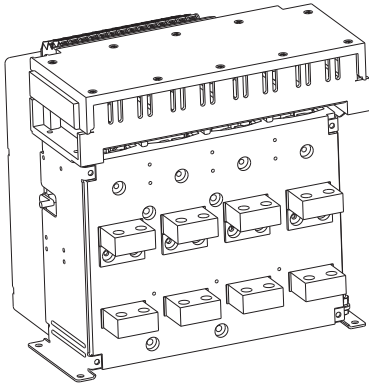

Busbar size and busbar interval

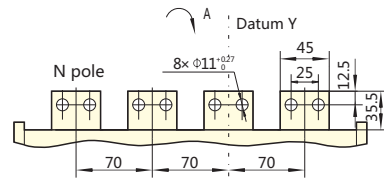

Installation and wiring

1600A draw-out type

Front view

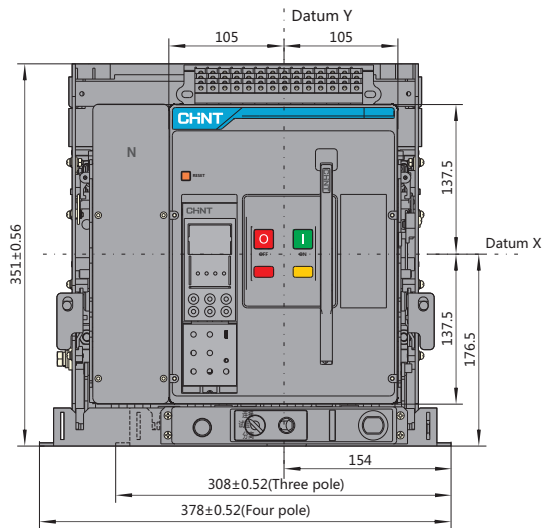

Side view

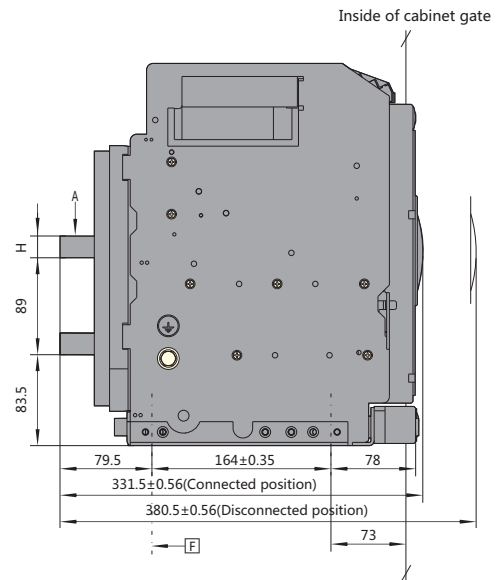

Hole size

Hole size of the base

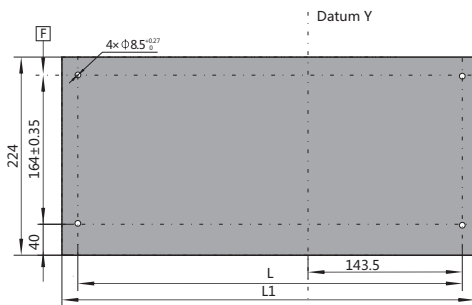

Schematic diagram of the overall size of the bottom surface and the installation hole pitch

H	L	L1	Remark
5	287±0.46	308	In=400A~630A Three pole
8	287±0.46	308	In=800A~1250A Three pole
20	287±0.46	308	In=1600A Three pole
5	357±0.46	378	In=400A~630A Four pole
8	357±0.46	378	In=800A~1250A Four pole
20	357±0.46	378	In=1600A Four pole

Hole size of a panel

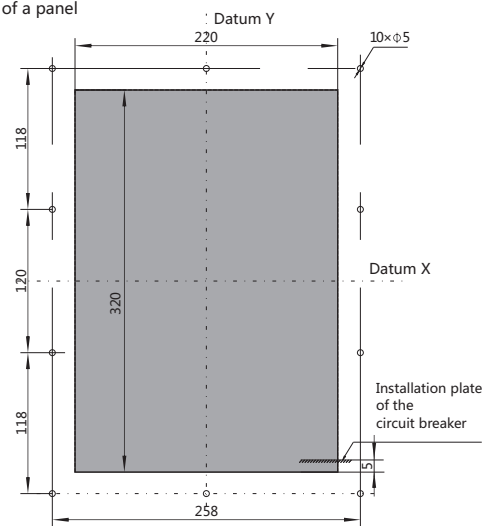

Ratio: 1:1.5 Hole size of a panel of the draw-out type circuit breaker

Horizontal connection

Side view

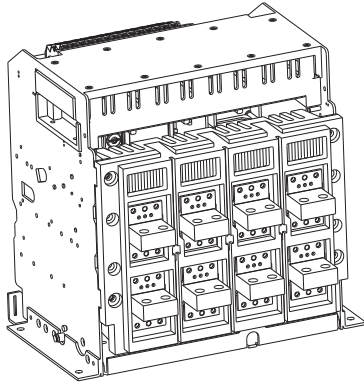

Busbar size and interval

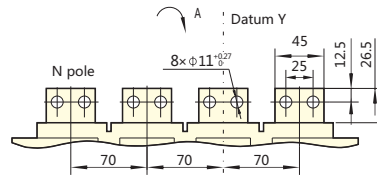

Installation and wiring

2000A fixed type

Front view

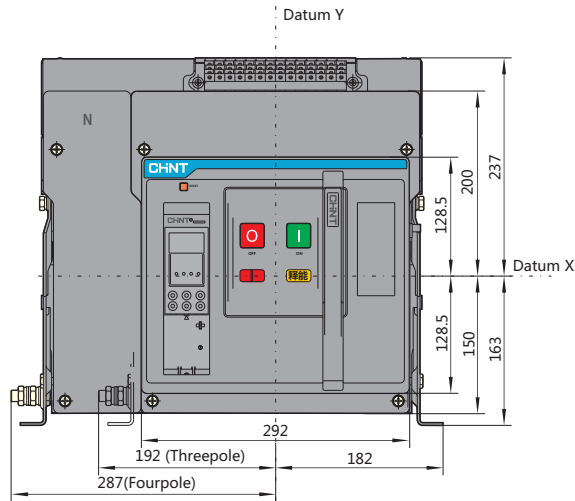

Side view

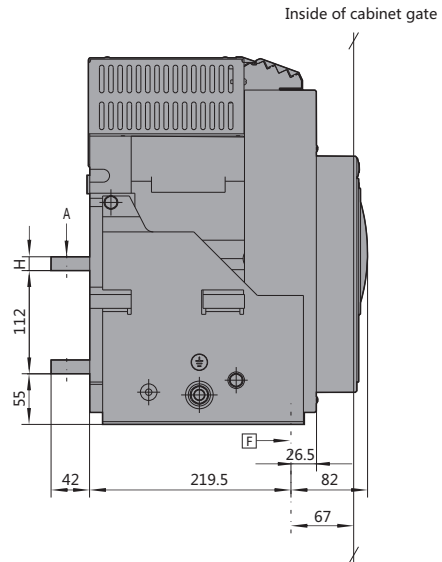

Hole size

Hole size of the base

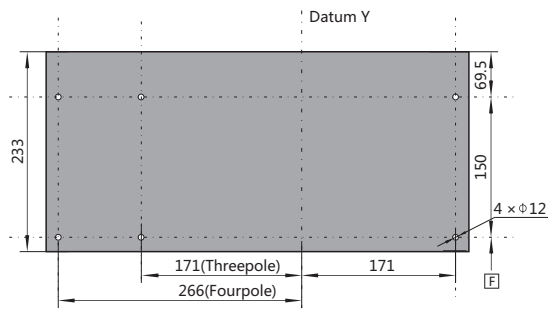

Schematic diagram of the overall size of the bottom surface and the installation hole pitch

Hole size of a panel

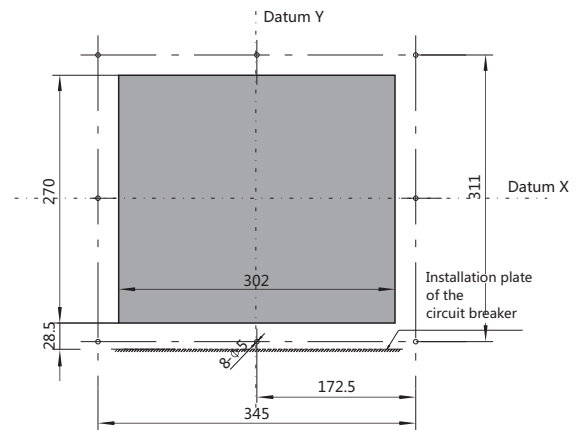

Hole of the panel

H	Remark
10	In=630A
15	In=800A~1600A
20	In=2000A

Horizontal connection

Side view

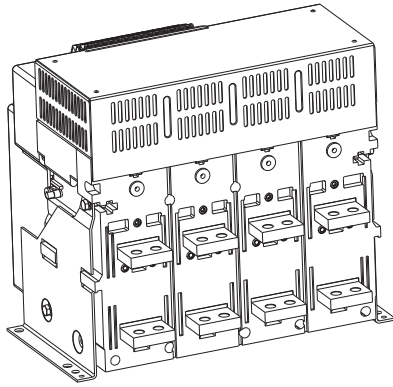

Busbar size and interval

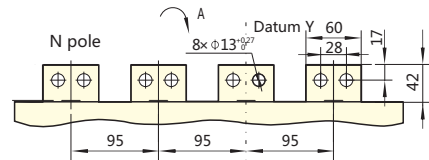

Installation and wiring

2000A draw-out type

Front view

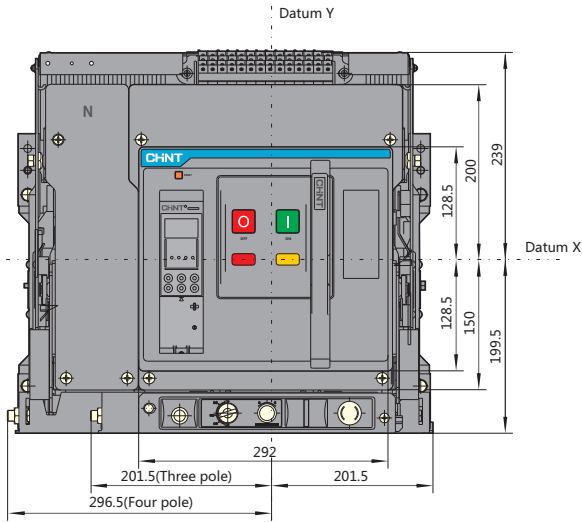

Side view

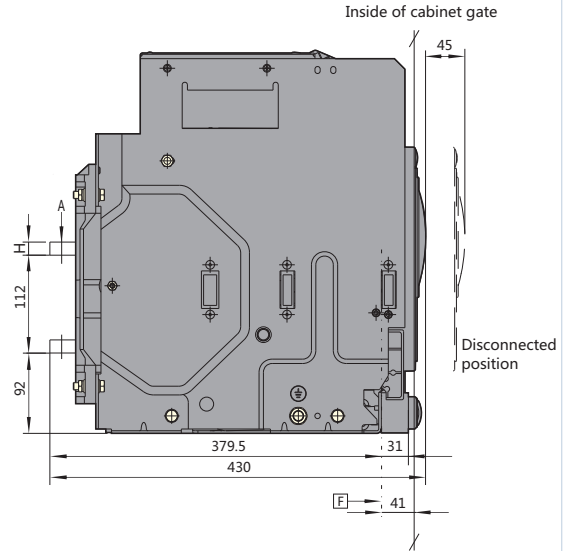

Hole size

Hole size of the base

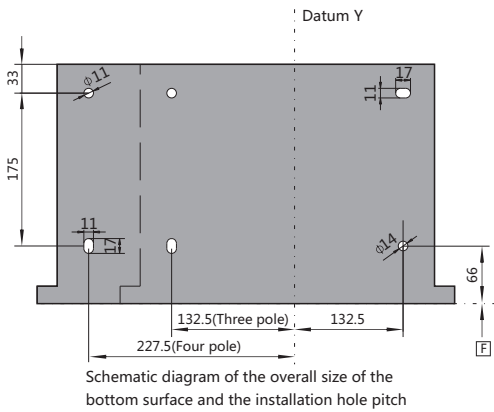

Hole size of a panel

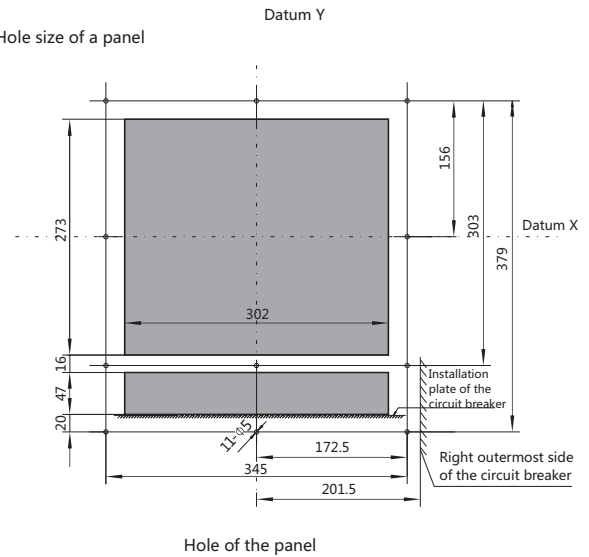

H	Remark
10	In=630A
15	In=800A~1600A
20	In=2000A

Horizontal connection

Side view

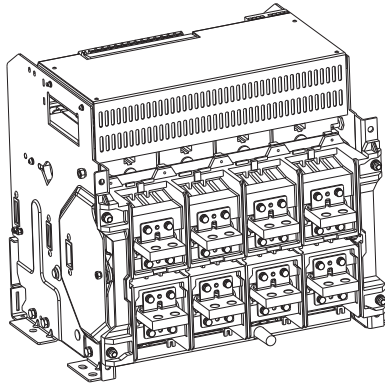

Busbar size and interval

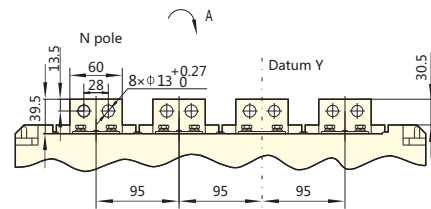

Installation and wiring

3200A fixed type

Front view

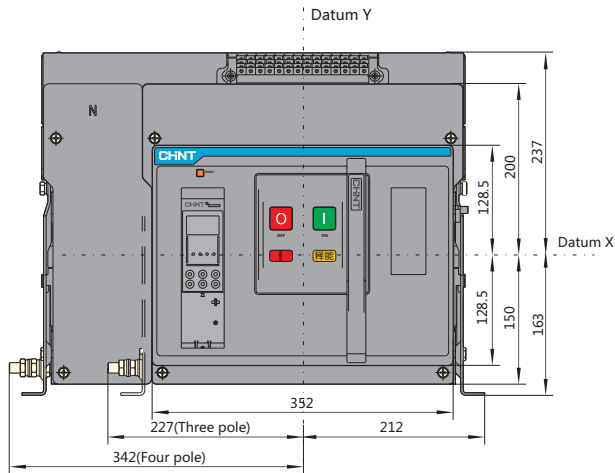

Side view

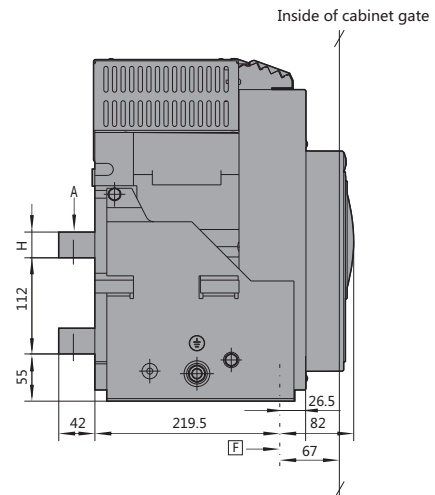

Hole size

Hole size of the base

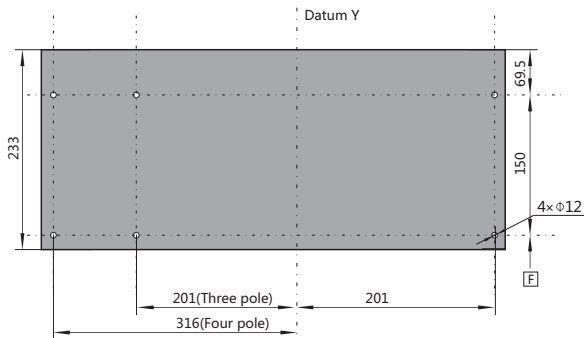

Schematic diagram of the overall size of the bottom surface and the installation hole pitch

Hole of the panel

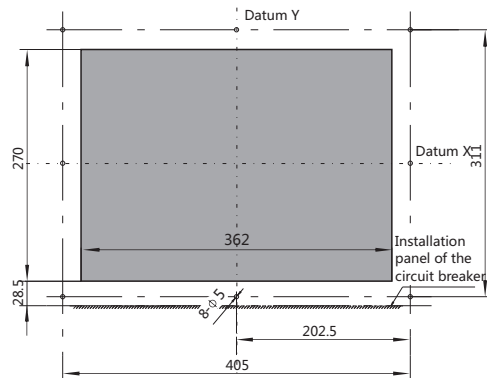

Horizontal connection

H	Remark
20	In=1600A~2500A
30	In=3200A

Horizontal connection

Side view

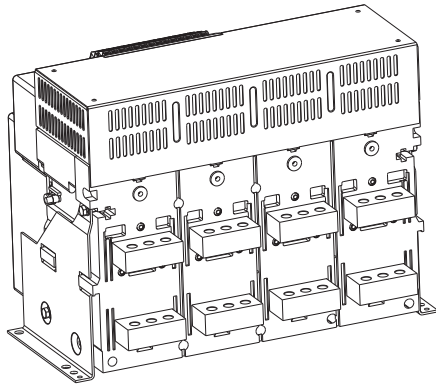

Busbar size and interval

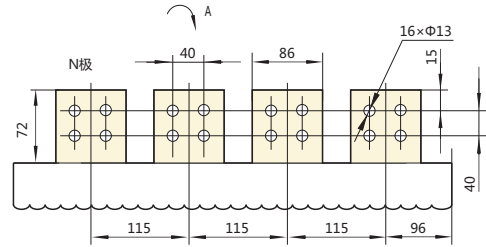

Horizontal onnection (default configuration)

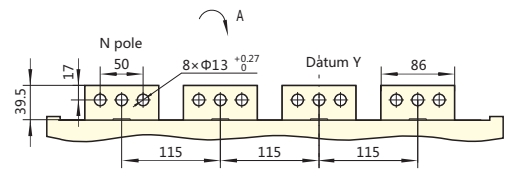

Horizontal short busbar

Installation and wiring

3200A draw-out type(Default configuration)

Front view

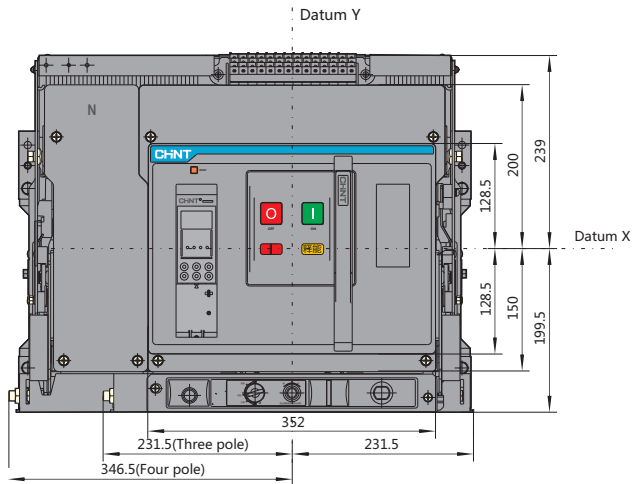

Side view

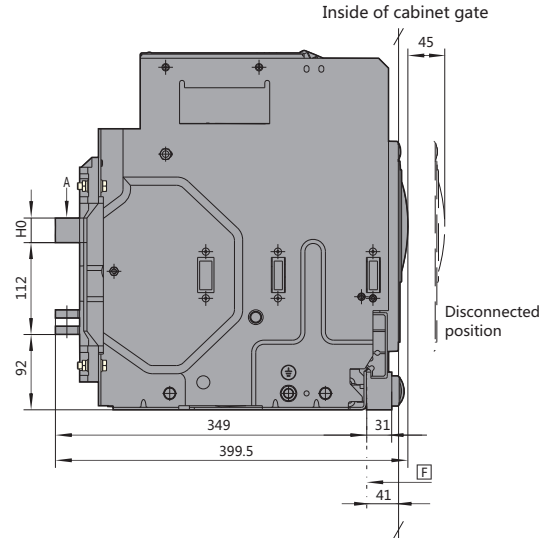

3200A draw-out type(Horizontal short busbar)

Front view

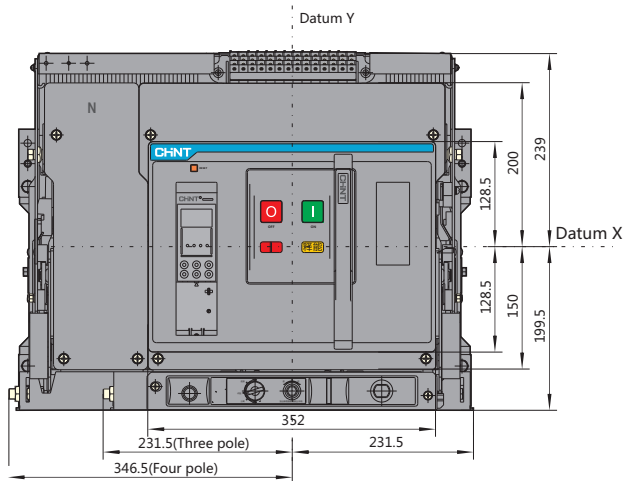

Side view

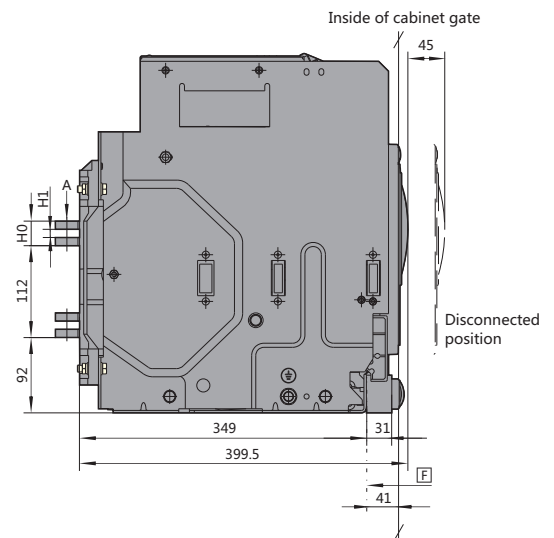

Hole size

Hole size of the base

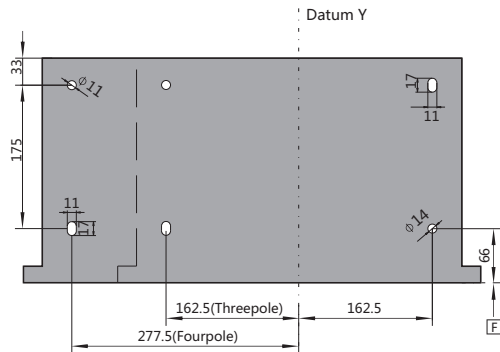

Schematic diagram of the overall size of the bottom surface and the installation hole pitch

Hole size of a panel

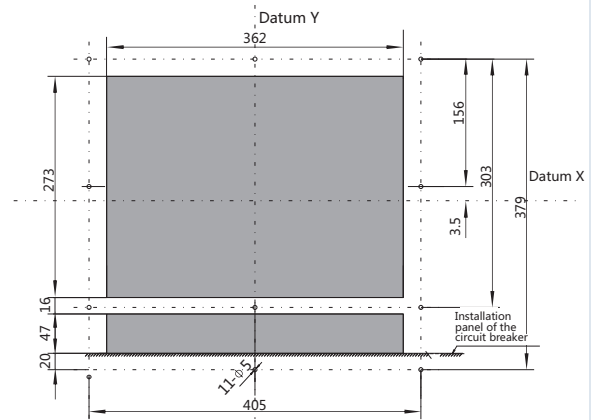

Hole of the panel

H0	H1	Remark
20	0	In=1600A~2500A
30	$10^{+0.1}_0$	In=3200A

Horizontal connection

Side view

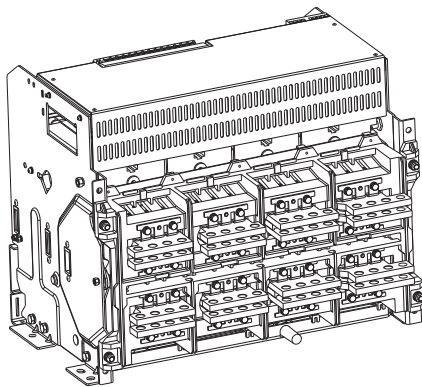

Busbar size and interval

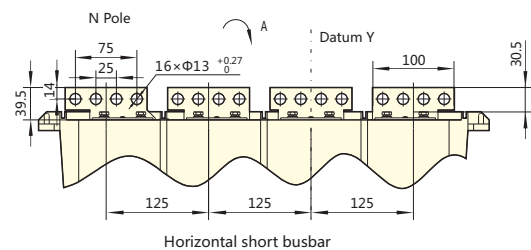
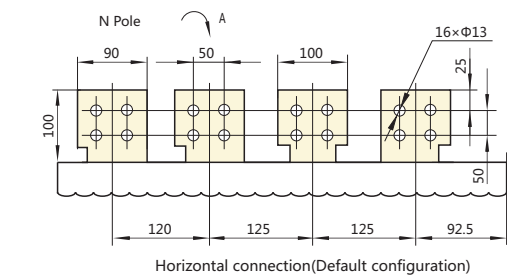

Installation and wiring

4000A fixed type

Front view

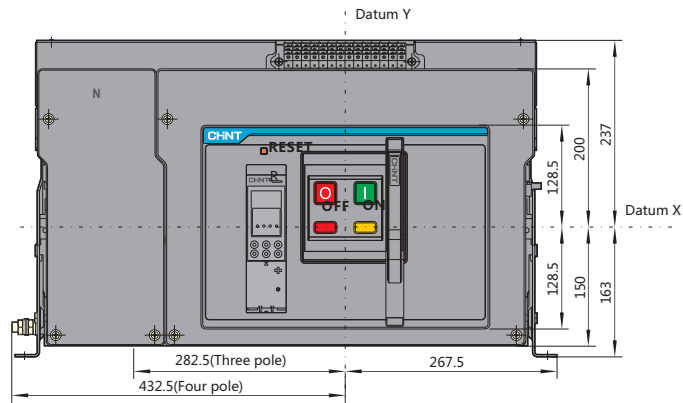

Side view

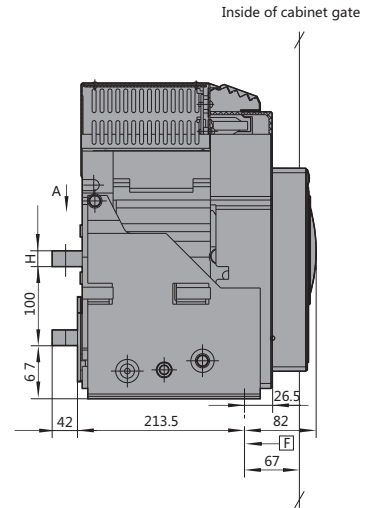

Hole size

Hole size of the base

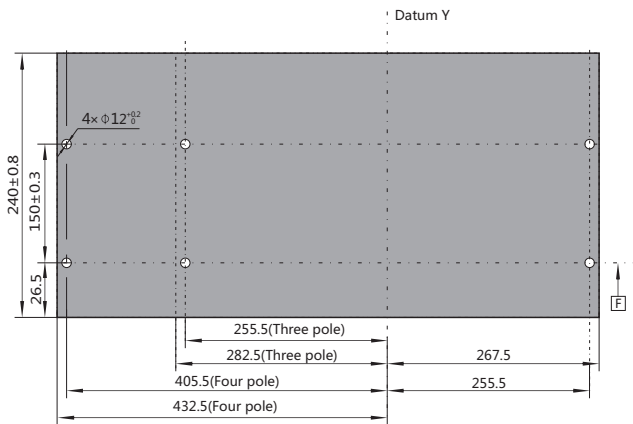

Schematic diagram of the overall size of the bottom surface and the installation hole pitch

Hole size of a panel

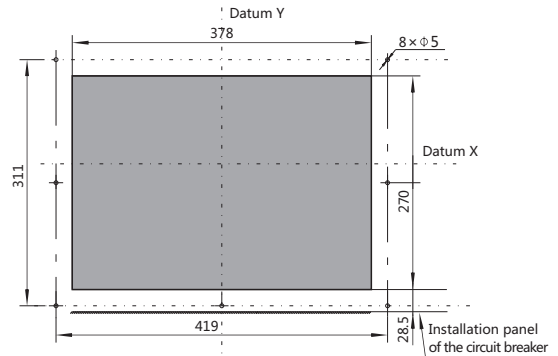

Ratio 1:2 Hole size of the panel of the fixed type circuit breaker

H	Remark
16	In=3200A
20	In=3600A~4000A

Horizontal connection

Side view

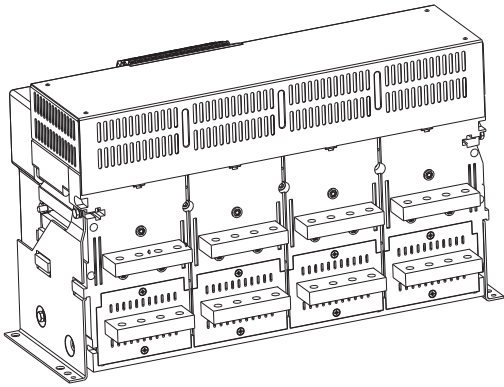

Busbar size and interval

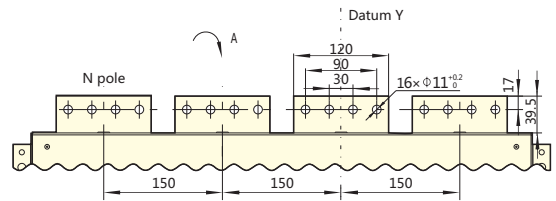

Installation and wiring

4000A draw-out type

Front view

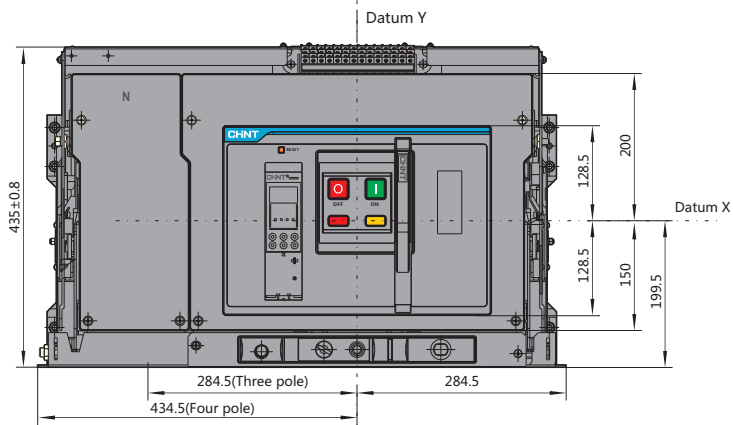

Side view

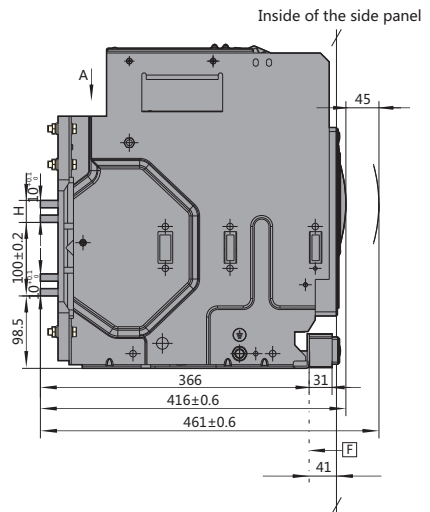

Hole size

Hole size of the base

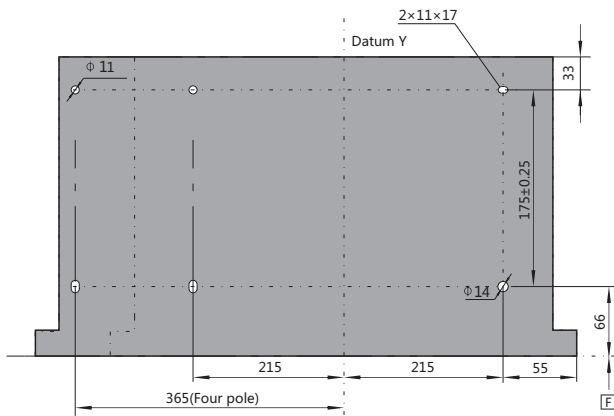

Schematic diagram of the overall size of the bottom surface and the installation hole pitch

Hole size of a panel

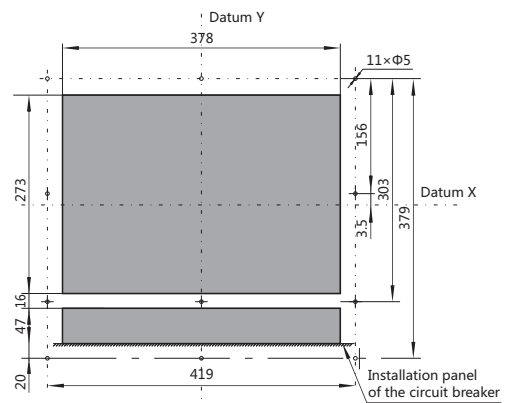

Ratio 1:1 Hole size of the panel of the draw-out type circuit breaker

H	Remark
26	In=3200A
30	In=3600~4000A

Horizontal connection

Side view

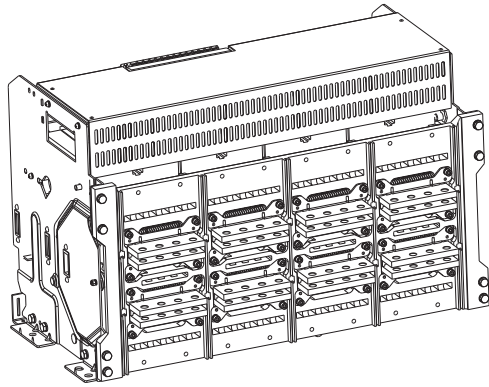

Busbar size and interval

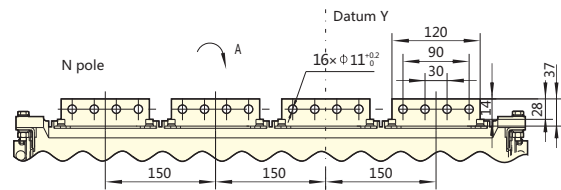

Installation and wiring

External transformer (Neutral CT) (3P+N mode)

External transformer (Neutral CT) dimension

The installation overall dimension of an external N-phase transformer is as below when the controller is of 3P+N type.
The transformer is provided by the manufacturer. A connection copper bar and an installation support are manufactured by users.

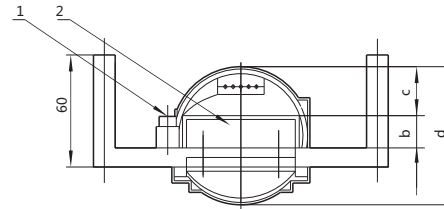
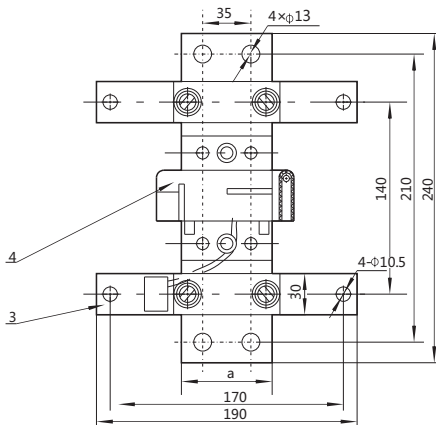

1-Wiring panel 2-Busbar 3-Fixation panel 4-Transformer

Frame size	a	b	c	d
1600	45	20	40	88
2000	60	20	34	89
3200	80	20	35	110
4000	120	20	16	58

4CT Type earth current transformer

Structural dimension of external earth current transformer (W type)

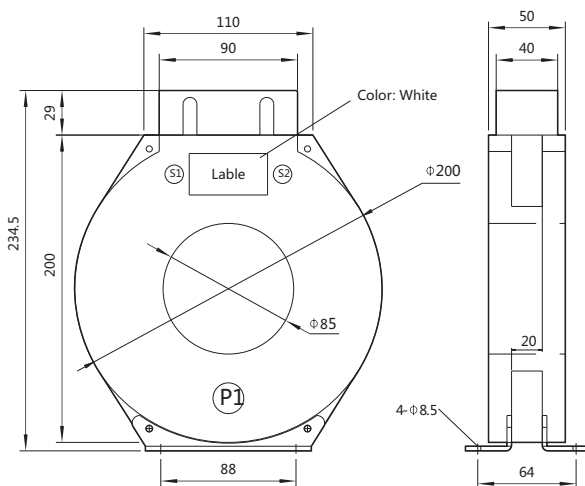

CTB-2 Type earth current transformer

Structural dimension of external earth current transformer (W type)

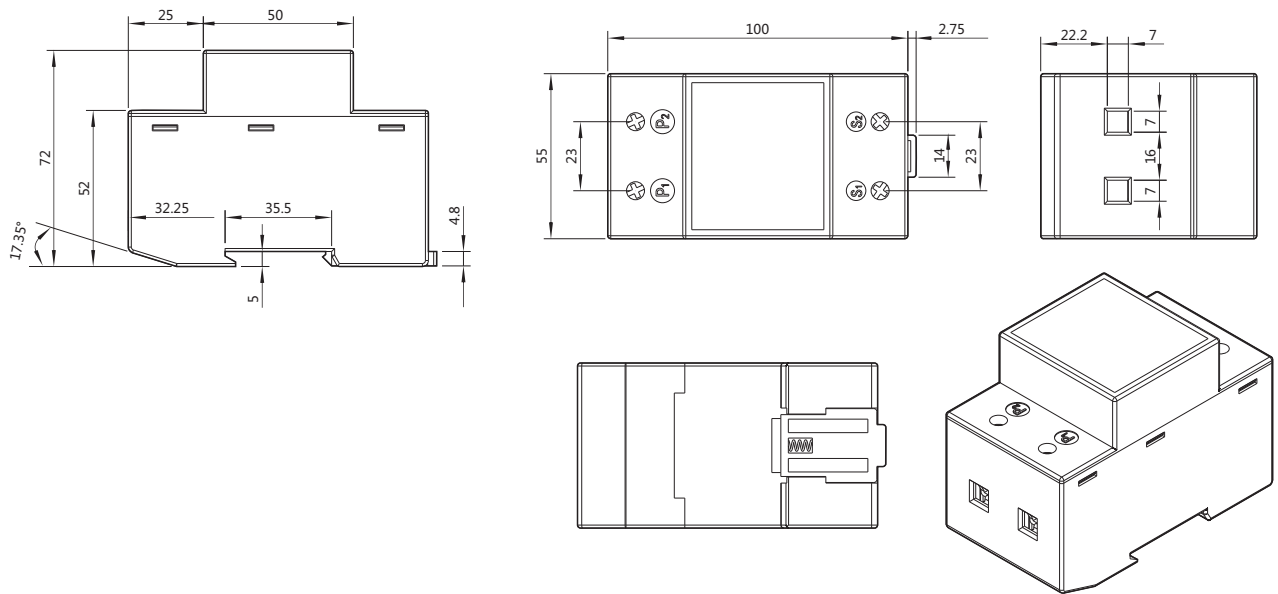

Undervoltage time delay controller

Installation overall dimension of undervoltage time-delay controller which is required to be plugged in the undervoltage time-delay tripper



Installation and wiring

Secondary circuit wiring

1600A frame

M/A type control unit

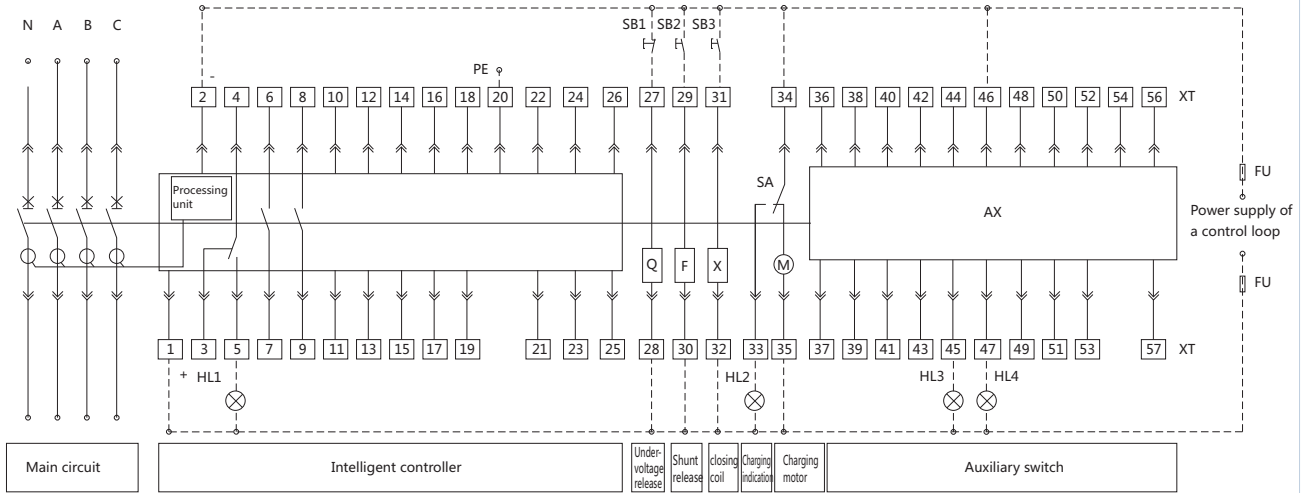

AX auxiliary contact type

For user

Four groups of adapters (Default) Six groups of adapters

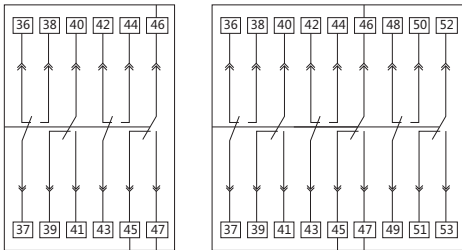

Q-Undervoltage release F-Shunt release X-Closing coil
M-Charging motor SA-Limited XT-Wiring terminal
AX-Auxiliary contact SB1-Emergency stop button
SB2-Tripping push button SB3-Closing push button HL1-Failure indication lamp
HL2-Charging indication lamp HL3-Tripping indication lamp
HL4-Closing indication lamp FU-Fuse (6A)
1#, 2#: Power supply of intelligent controller
3#~5#: Tripping alarm contact (4-common point)
6#, 9#: Auxiliary contact, normally open contact
10#~11#: Empty
12#~19#: Empty
20#: PE line
21#~24#: Empty

25#~26#: External N-phase transformer input signal contacts. Conventional products are empty. When an external transformer is required to be attached for special order of users, they are external transformer signal input contacts.
27#, 28#: Undervoltage release
29#, 30#: Shunt release
31#, 32#: Closing coil
33#, 34#: Charging indication
34#, 35#: Charging motor
36#~56#: Auxiliary contact
Conventional products are four groups of adapters, and six groups of adapters can be provided for special order for users.
Note: The full line section is connected, and the dot line is connected by customers.

1600A frame

P/H type control unit

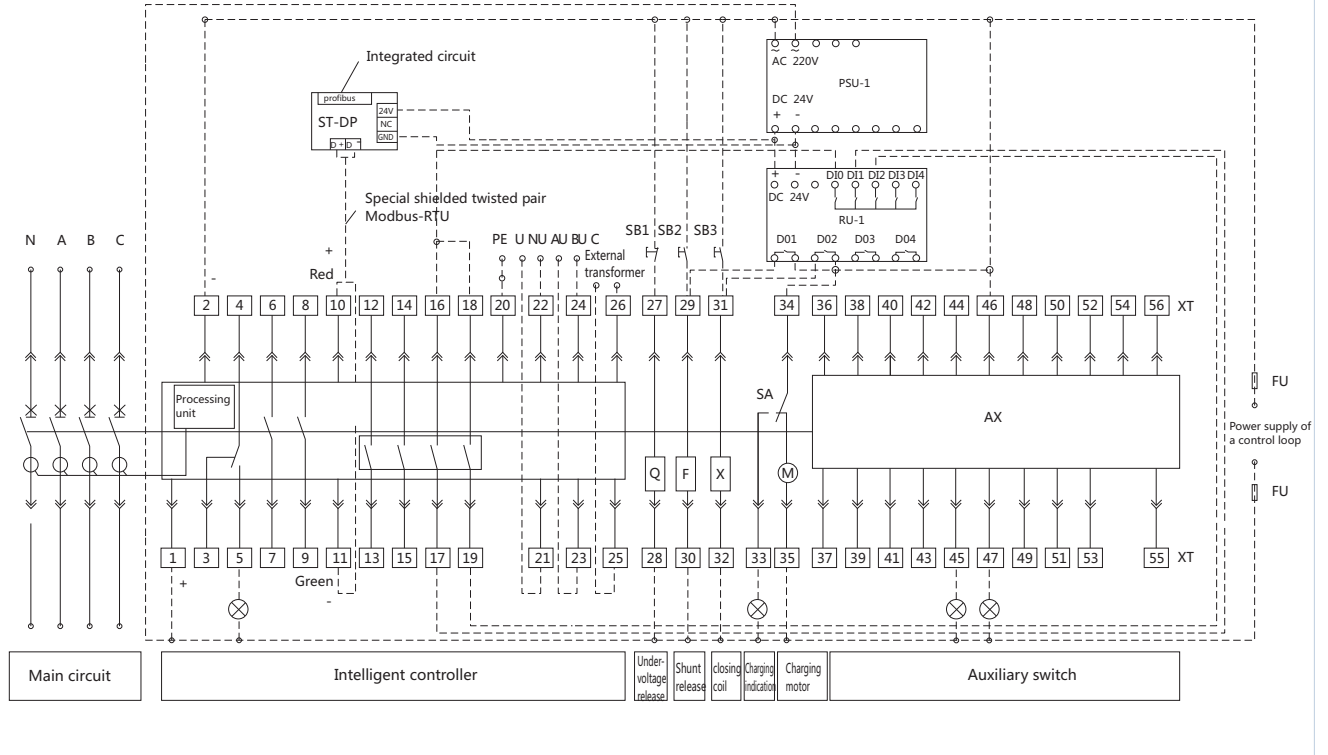

AX auxiliary contact type

For user

Four groups of adapters (Default) Six groups of adapters

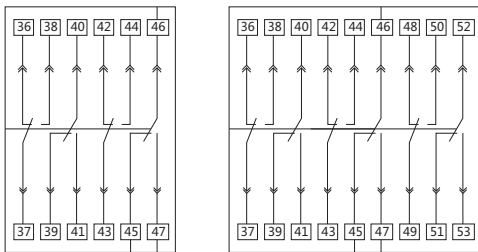

- Q-Undervoltage release F-Shunt release
- X-Closing coil M-Charging motor
- SA-Limited switch XT-Wiring terminal AX-Auxiliary contact
- SB1-Emergency stop button SB2-Tripping push button
- SB3-Closing push button HL1-Failure indication lamp
- HL2-Charging indication lamp
- HL3-Tripping indication lamp HL4-Closing indication lamp
- FU-Fuse (6A) PSU-1—power module
- 1#, 2#: Power supply of intelligent controller
- 3#~5#: Tripping alarm contact (4-common point)
- 6#~9#: Auxiliary contact, normally open contact
- 10#~11#: Defaulted communication output contact for a H type intelligent controller. P type is empty
- 12#~19#: Four groups of programmable output contacts

H type intelligent controller with a programmable output contact outputs in default: 12#, 13#: load 1 alarm, 14#, 15#: load 2 alarm, 16#, 17#: tripping signal output, 18#, 19#: Closing signal output

P type intelligent controller with a programmable output contact outputs in default: 12#, 13#: load 1 alarm, 14#, 15#: load C alarm, 16#, 17#: self-diagnosis alarm, 18#, 19#: failure tripping, 20#: PE line.

21#~24#: voltage display input signal contact

P/H type intelligent controller 21#:N-phase voltage signal 22#: A-phase voltage signal 23#:B-phase voltage signal, 24#: C-phase voltage signal

25#~26#: External N-phase transformer or external earth current transformer input signal contacts. Conventional products are empty. When an external transformer is required for special order for users, they are external transformer signal input contacts.

27#, 28#: Undervoltage release

29#, 30#: Shunt release

31#, 32#: Closing coil

33#, 34#: Charging indication

34#, 35#: Charging motor

36#~56#: Auxiliary contact

Conventional products are four groups of adapters, and six groups of adapters can be provided for special order for users.

ST-DP: DP protocol module. When the upper computer communication protocol is Modbus-RTU, the ST-DP protocol module is not required. When the upper computer communication protocol is Profibus-DP, the Modbus-RTU protocol module is required to be converted into Profibus-DP protocol by the ST-DP protocol module, extra fee needed.

RU-1: relay module. The circuit breaker is used for tripping and switching via remote control, and is used for tripping and switching signal energy amplification, extra fee needed.

Note: The full line section is connected, and the dot line should be connected by customers.

Installation and wiring

2000-4000A frame

M/A type control unit

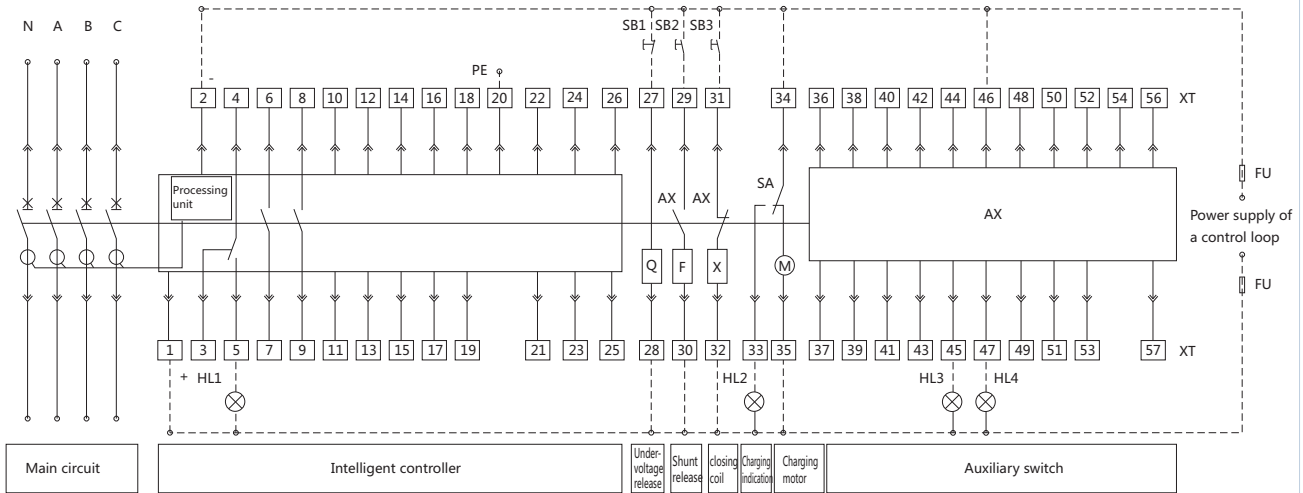

AX auxiliary contact type

For user

Four groups of adapters (Default)

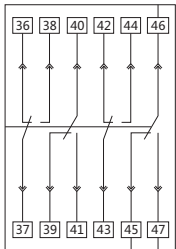

Five groups of adapters

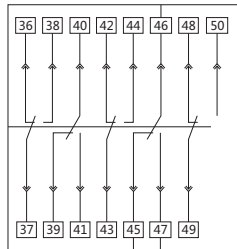

Three-open three-closed auxiliary contact

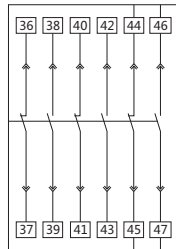

Four-open four-closed auxiliary contact

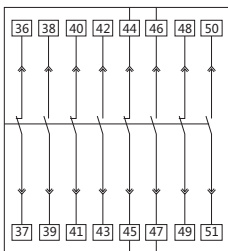

Five-open five-closed auxiliary contact

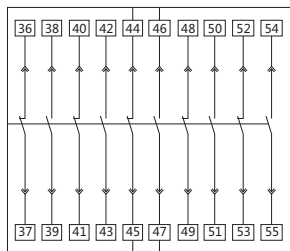

Q-Undervoltage release F-Shunt release X-Closing coil
M-Charging motor SA-Limited switch XT-Wiring terminal
AX-Auxiliary contact SB1-Emergency stop button SB2-Tripping push button
SB3-Closing push button HL1-Failure indication lamp
HL2-Charging indication lamp HL3-Tripping indication lamp
HL4-Closing indication lamp FU-Fuse (6A)
1#, 2#: Power supply of intelligent controller
3#~5#: Tripping alarm contact (4-common point)
6#~9#: Auxiliary contact, normally open contact
10#~11#: Empty
12#~19#: Empty
20#: PE line
21#~24#: Empty
25#~26#: External N-phase input signal contacts.
Conventional products are empty. When an external transformer is required to be attached for special order of users, they are external transformer signal input contacts.
27#, 28#: Undervoltage release
29#, 30#: Shunt release
31#, 32#: Closing coil
33#, 34#: Charging indication
34#, 35#: Charging motor
36#~56#: Auxiliary contact
Conventional products are four groups of adapters.
The three-open three-closed auxiliary contact, the four-open four-closed auxiliary contact, the five-open five-closed auxiliary contact, and five groups of adapters can be provided for the special order for users.
Note: 1. the full line section is connected, and the dot line should be connected by customers.
Note: 2. when the voltages of the controller of the 2000-4000 frame are AC 230V/AC 400V, the controller can be directly connected to 1#, 2# terminals. When the voltage is DC 220V/DC 110V, the controller can be connected to 1#, 2# terminals after the power supply module outputs DC 24V.

2000-4000A frame

P/H type control unit

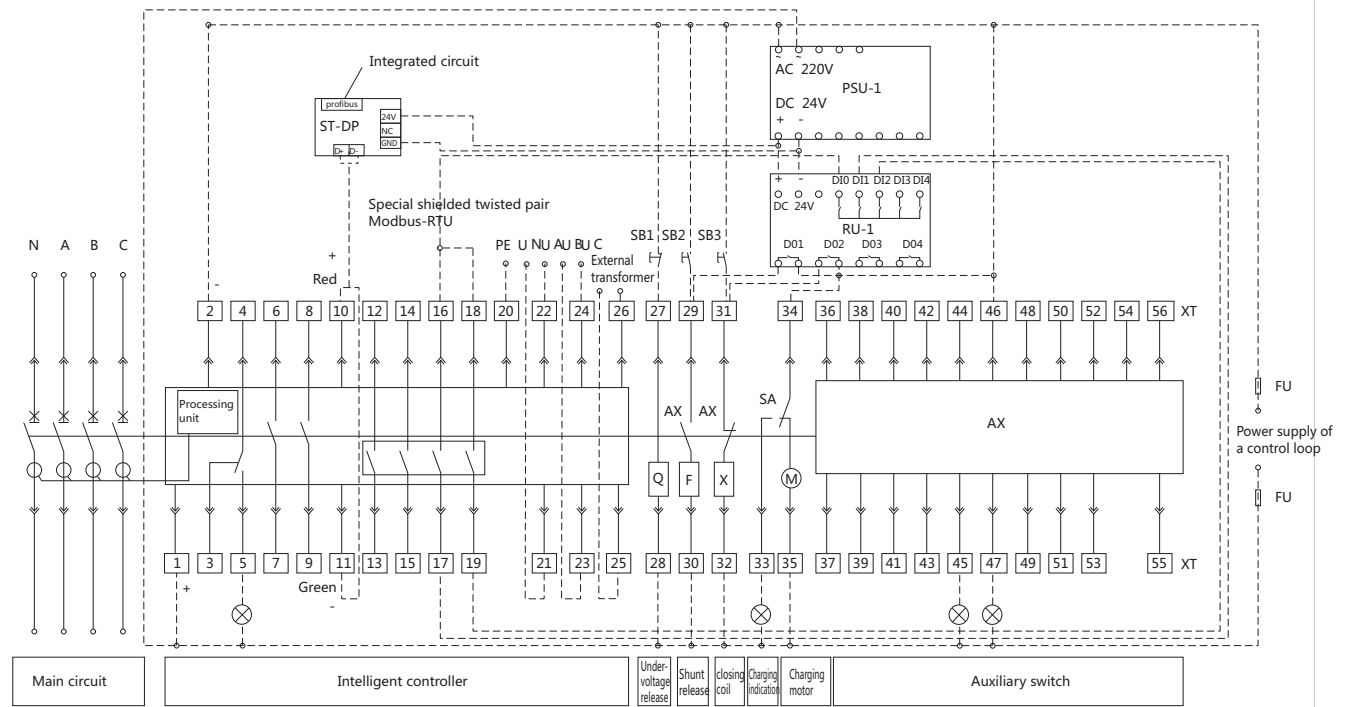

AX auxiliary contact type

For user

Four groups of adapters (Default)

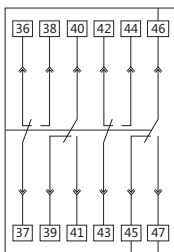

Five groups of adapters

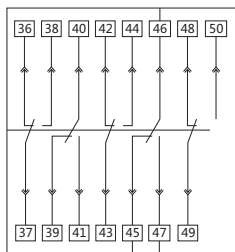

Three-open three-closed auxiliary contact

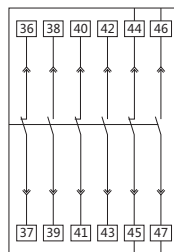

Four-open four-closed auxiliary contact

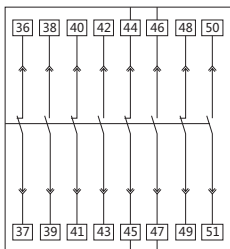

Five-open five-closed auxiliary contact

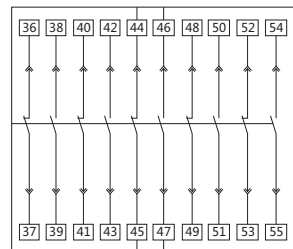

21#~24#: voltage display input signal contact

P/H type intelligent controller

21#: N-phase voltage signal, 22#: A-phase voltage signal

23#: B-phase voltage signal, 24#: C-phase voltage signal

25#~26#: External N-phase transformer or external earthing current transformer input signal contacts.

Conventional products are empty. When an external transformer is required for special order for users, they are external transformer signal input contacts.

27#, 28#: Undervoltage release, 29#, 30#: Shunt release

31#, 32#: Closing coil, 33#, 34#: Charging indication

34#, 35#: Charging motor

36#~56#: Auxiliary contact

Q-Undervoltage release F-Shunt release X-Closing coil

M-Charging motor SA-Limited switch XT-Wiring terminal

AX-Auxiliary contact SB1-Emergency stop button SB2-Tripping push button

SB3-Closing push button HL1-Failure indication lamp

HL2-Charging indication lamp HL3-Tripping indication lamp

HL4-Closing indication lamp FU-Fuse (6A) PSU-1—power module

1#, 2#: Power supply of intelligent controller

3#~5#: Tripping alarm contact (4-common point)

6#~9#: Auxiliary contact, normally open contact

10#~11#: Defaulted communication output contact for a H type intelligent controller.

P type is empty

12#~19#: Four groups of programmable output contacts

H type intelligent controller with a programmable output contact outputs in default:

12#, 13#: load 1 alarm, 14#, 15#: load 2 alarm, 16#,17#: tripping signal output,

18#, 19#: switching signal output.

P type intelligent controller with a programmable output contact outputs in default:

12#, 13#: load 1 alarm, 14#, 15#: load C alarm, 16#,17#: self-diagnosis alarm,

18#, 19#: failure tripping.

20#: PE line.

Conventional products are four groups of adapters. The three-open three-closed auxiliary contact, the four-open four-closed auxiliary contact, the five-open five-closed auxiliary contact, and five groups of adapters can be provided for the special order for users.

ST-DP: DP protocol module. When the upper computer communication protocol is Modbus-RTU, the ST-DP protocol module is not required. When the upper computer communication protocol is Profibus-DP, the Modbus-RTU protocol module is required to be converted into Profibus-DP protocol by the ST-DP protocol module, extra fee needed.

RU-1: relay module. The circuit breaker is used for breaking and making via remote control, and is used for breaking and making signal energy amplification, extra fee needed.

Note: 1. the full line section is connected, and the dot line should be connected by customers.

Note: 2. when the voltages of the controller of the 2000-4000 frame are AC 230V/AC 400V, the controller can be directly connected to 1#, 2#terminals.

When the voltage is DC 220V/DC 110V, the controller can be connected to 1#, 2# terminals after the power supply module outputs DC 24V.

Chassis position indicator device

Wiring diagram

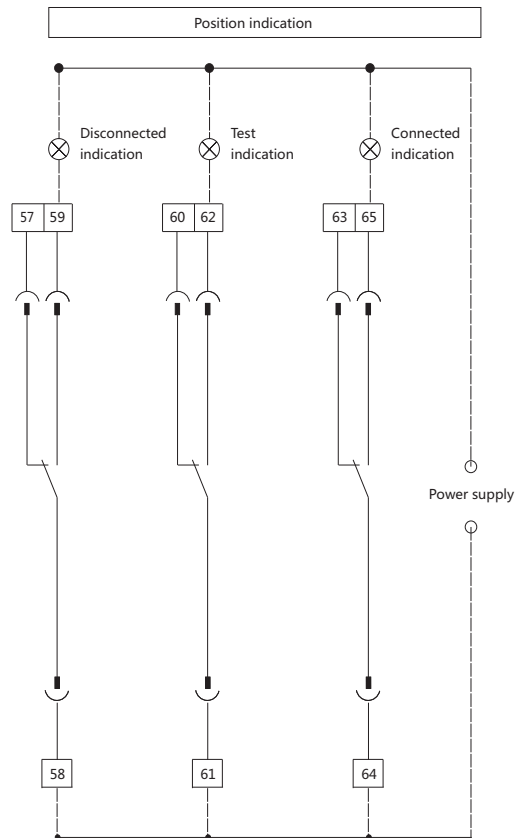

Operation requirements:

1. The chassis indication device can indicate the positions including "disconnected", "test" and "connected" which are completely or partially used according to the requirements of order.
2. When the body of the draw-out type circuit breaker is pushed from the "disconnected" position to the "test" position, 57# and 58# terminals should be transferred from connection into disconnection, and 58# and 59# terminals should be transferred from disconnection to connection.
3. When the body of the draw-out type circuit breaker is pushed from the "disconnected" position to the "test" position, 60# and 61# terminals should be transferred from connection into disconnection, and 61# and 62# terminals should be transferred from disconnection to connection. There is sufficient safety distance between the bus of the circuit breaker body and a bridge-type contact of the safety shutter, and tripping and switching operation can be carried out reliably.
4. When the body of the draw-out type circuit breaker is switched from the "test" position to the "connected" position, NXA16 type secondary circuit has no clearance. The NXA20-40 type safety shutter swing continuously after sending out the "cracking" sound, and the safety shutter jiggle handle rotates within 15 circles. 63# and 64# terminals are being transferred from connection to disconnection. 64# and 65# terminals are transferred from disconnection to connection. The busbar of circuit breaker body is required to be reliably inserted into the bridge-type contact of the chassis base, and reliably bear the main circuit current to operate.
5. When the body of the draw-out type circuit breaker is pushed from the "connected" position to the "test" position, 60# and 61# terminals should be transferred from connection into disconnection, and 61# and 62# terminals should be transferred from disconnection to connection. There is sufficient safety distance between the busbar of the circuit breaker body and a bridge-type contact of the chassis, and tripping and switching operation can be carried out reliably.
6. When the body of the draw-out type circuit breaker swings from the "test" position to the "disconnected" position, 57# and 58# terminals should be transferred from connection to disconnection, and 58# and 59# terminals should be transferred from disconnection to connection, and at the same time, the circuit breaker body still cannot be drawn out, and needs to swing toward the "disconnected" position until the handle cannot swing any more, and meanwhile, the circuit breaker body can be drawn out. After the circuit breaker is pulled out, 57# and 58# terminals should be transferred from disconnection to connection, and 58# and 59# terminals should be transferred from connection to disconnection.
7. In the position transfer operation process of the chassis, the operation can only be stopped when the indicator points to "disconnected", "test" and "connected" or the position indicator cannot display the position of the circuit breaker body in the chassis correctly.

LSI curves

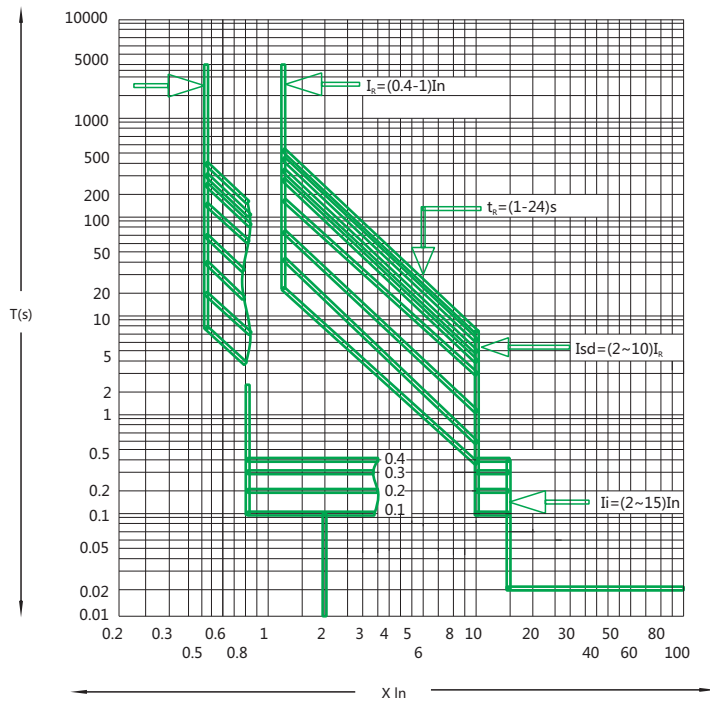

Earth fault protection curves

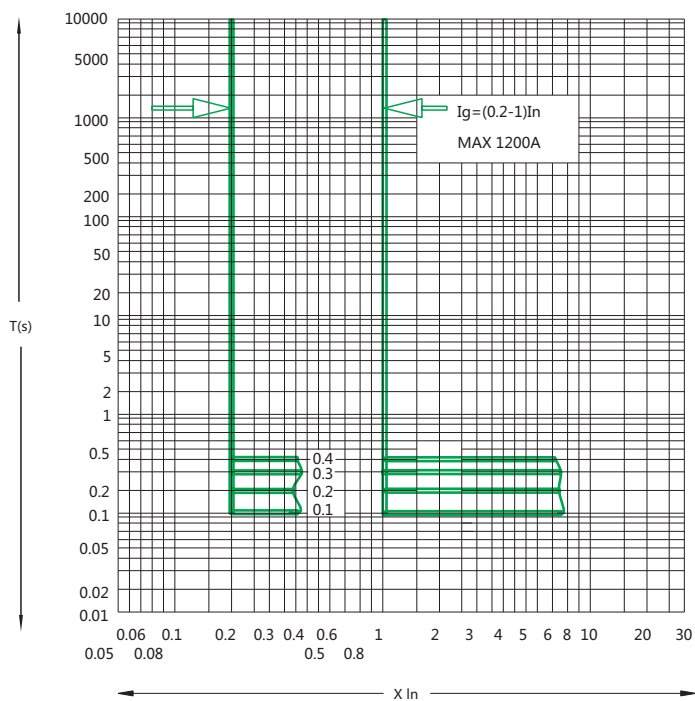

Annex II: Configuration

Standard configuration	1600A frame		2000A frame		3200A frame		4000A frame	
	Fixed type	draw-out type	Fixed type	draw-out type	Fixed type	draw-out type	Fixed type	draw-out type
Circuit breaker body	■	■	■	■	■	■	■	■
Chassis		■		■		■		■
Intelligent controller	■	■	■	■	■	■	■	■
Vertical and horizontal connection	■	■	■	■	■	■	■	■
ON/OFF indication contact 4CO	■	■	■	■	■	■	■	■
Failure tripping indication contact	■	■	■	■	■	■	■	■
Motor operating mechanism	■	■	■	■	■	■	■	■
Closing coil	■	■	■	■	■	■	■	■
Shunt release	■	■	■	■	■	■	■	■
Door frame	■	■	■	■	■	■	■	■

Optional accessories	1600A frame		2000A frame		3200A frame		4000A frame	
	Fixed type	draw-out type	Fixed type	draw-out type	Fixed type	draw-out type	Fixed type	draw-out type
Standard undervoltage release	■	■	■	■	■	■	■	■
Adjustable time-delay undervoltage unit	■	■	■	■	■	■	■	■
Rapid secondary wiring terminal	■	■	■	■	■	■	■	■
Pushbutton lock	■	■	■	■	■	■	■	■
"Disconnected" position padlock		■		■		■		■
Safety shutters padlock		■		■		■		■
Body lock	■	■	■	■	■	■	■	■
Position door interlock		■		■		■		■
State door interlock		■		■		■		■
ON/OFF indication contact 6CO	■	■						
ON/OFF indication contact 5NO + 5NC			■	■	■	■	■	■
ON/OFF indication contact 3NO + 3NC			■	■	■	■	■	■
ON/OFF indication contact 4NO+4NC			■	■	■	■	■	■
ON/OFF indication contact 5CO			■	■	■	■	■	■
"Connected", "Disconnected" and "test" position indication contact		■		■		■		■
Mechanical interlock	■	■	■	■	■	■	■	■
Source-changeover controller	■	■	■	■	■	■	■	■
External transformer (Neutral CT)	■	■	■	■	■	■	■	■
Earth current transformer and accessories thereof	■	■	■	■	■	■	■	■
Interphase barrier	■	■	■	■	■	■	■	■

Annex III: Selection table

Frame size	1600A		2000A			3200A			4000A		
Circuit breaker	N <input type="checkbox"/>	H <input type="checkbox"/>	N <input type="checkbox"/>	S <input type="checkbox"/>	H <input type="checkbox"/>	N <input type="checkbox"/>	S <input type="checkbox"/>	H <input type="checkbox"/>	N <input type="checkbox"/>	S <input type="checkbox"/>	H <input type="checkbox"/>
Rated current	400A <input type="checkbox"/>		630A <input type="checkbox"/>			1600A <input type="checkbox"/>			3200A <input type="checkbox"/>		
	630A <input type="checkbox"/>		800A <input type="checkbox"/>			2000A <input type="checkbox"/>			3600A <input type="checkbox"/>		
	800A <input type="checkbox"/>		1000A <input type="checkbox"/>			2500A <input type="checkbox"/>			4000A <input type="checkbox"/>		
	1000A <input type="checkbox"/>		1250A <input type="checkbox"/>			3200A <input type="checkbox"/>					
	1250A <input type="checkbox"/>		1600A <input type="checkbox"/>								
Number of poles	3 pole <input type="checkbox"/>		4 pole <input type="checkbox"/>								
Installation modes	Horizontal draw-out <input type="checkbox"/>					Fixed and horizontal <input type="checkbox"/>					
Intelligent controller	M type <input type="checkbox"/>	A type <input type="checkbox"/>	P type <input type="checkbox"/>	PT type <input type="checkbox"/>	H type <input type="checkbox"/>	HT type <input type="checkbox"/>					
Shunt release and motor operation	Closing coil <input type="checkbox"/>					Shunt release <input type="checkbox"/>					
	AC220/230/240V <input type="checkbox"/>		AC380/400/415V <input type="checkbox"/>			DC110V <input type="checkbox"/>		DC220V <input type="checkbox"/>			
Undervoltage release (Match)	UVT <input type="checkbox"/>		UVTD <input type="checkbox"/>								
	AC220/230/240V <input type="checkbox"/>		AC380/400/415V <input type="checkbox"/>								
Auxiliary contact indication	Disconnected position <input type="checkbox"/>		Test position <input type="checkbox"/>			Connected position <input type="checkbox"/>					
Connection accessories	Interphase barrise <input type="checkbox"/>		Rapid secondary wiring terminal (Match) <input type="checkbox"/>								
Controller accessories (Match)	External transformer: Earth current transformer <input type="checkbox"/>					External transformer (Neutral CT) <input type="checkbox"/>					
	Note: ¹ Neutral CT is only applicable to 3P+N ² The earth current transformer should be selected when customers select earth current return type earthing protection.										
Lock mechanism (Match)	Pushbutton lock <input type="checkbox"/>		Safety shutters padlock <input type="checkbox"/>			Body lock <input type="checkbox"/>		One-lock one-key <input type="checkbox"/>		Two-locks one-key <input type="checkbox"/>	
	Three-locks two-keys <input type="checkbox"/>		"Disconnected" position padlock <input type="checkbox"/>			Door interlock (Body) <input type="checkbox"/>		Door interlock (chassis) <input type="checkbox"/>			
Mechanical interlock (Match)	2 "Normal" and 1 "Replacement" <input type="checkbox"/>		2 "Incoming" and 1 "Busbar" <input type="checkbox"/>								
Source-changeover controller (Match)	2 "Normal" and 1 "Replacement" <input type="checkbox"/>		2 "Incoming" and 1 "Busbar" <input type="checkbox"/>								

Annex IV: Earth fault protection

Description of NXA earth fault protection

Residual current earth fault type protection

- A three-pole circuit breaker achieves earth fault protection by detecting whether the sum of three current vectors is zero via three internal current transformer.

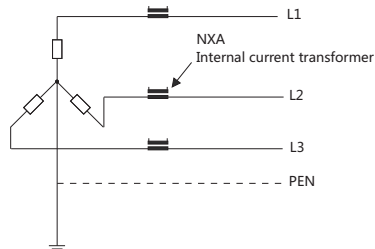

- A four-pole circuit breaker achieves earth fault protection by detecting whether the sum of three phase of current vectors and N phase of current vectors via four internal current transformer.

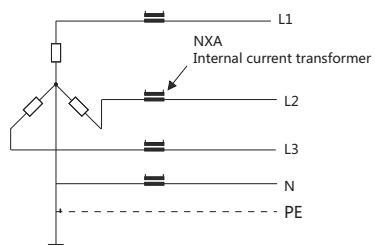

- A 3P+N system achieves vector by externally connecting an N-pole transformer to a three-pole circuit breaker and calculating the vector.

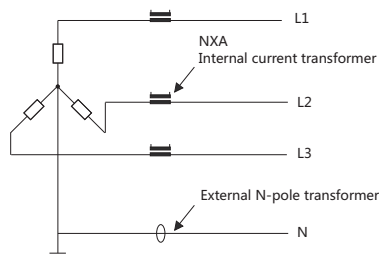

Note:

- ① The detail information of external N-pole transformer is seen in P41.
- ② The N-pole current transformer is specially configured by the company, and the default leading wire length is 2 meters.
- ③ When adopt 3PT type, ground fault protection can only apply to balance load application, if it is imbalance load, the ground fault function should be closed or setting value must be upper on imbalance current, or the intelligent controller will misoperate.
- ④ When adopt (3P+N)T type, the maximon distance between transformer and circuit breaker should be within 5 meters. The loading wire of transformer exceed 2 meters should sepciatly noted when order.

- Fig.1 displays a fault at the load side of the NXA circuit breaker. The fault current only flows through one phase. If the sum of three phase of current vectors detected by four current transformers is higher than the set threshold value, an intelligent control unit will activate the difference type earth fault protection function. The type of earth fault protection achieves the earth fault protection at the load side.

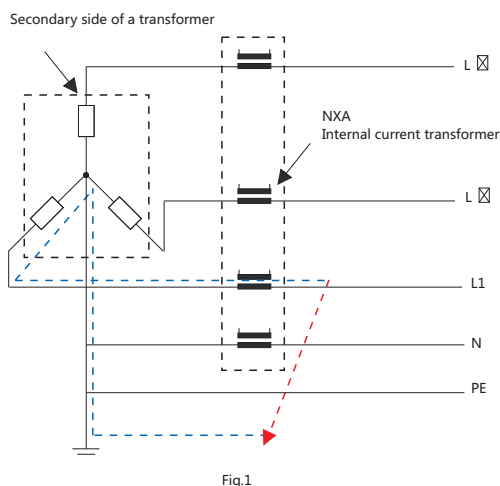

Annex IV: Earth fault protection

Earth current type earth fault protection

Earth fault protection is realized at a star-shaped central point of the transformer by an earth transformer

An earth transformer can be configured on a central conductor of a star-shaped contact of the transformer under the condition that the circuit breaker protects a medium/low-voltage transformer. P/H type controller is required to be configured on the circuit breaker, and an external earth transformer is selected. The earth transformer can detect the earth fault current at the power supply side and the load side of the NXA circuit breaker. As shown below:

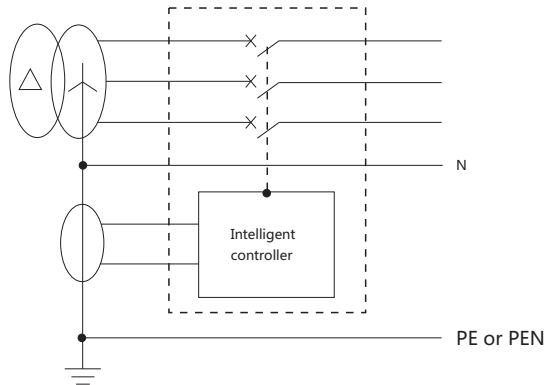

As shown below, the earth fault at the power supply side of the NXA circuit breaker can be examined by installing an external earth current transformer, and meanwhile, the earth fault at the load side of the NXA circuit breaker also can be detected.

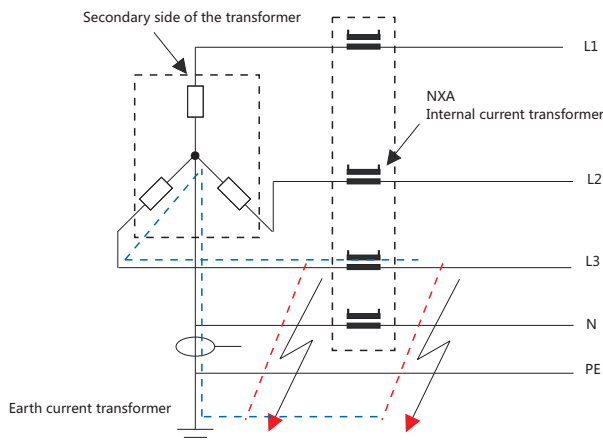

Dual earth fault protection

NXA P/H type controller has a unique feature: the installation of two independent earth fault protection curves is permissible, so that two kinds of configurations can be managed at the same time. The release can differentiate unlimited regional earth faults because of the feature to command the NXA circuit breaker to trip and the limited regional earth fault to command the medium-voltage circuit breaker to strip.

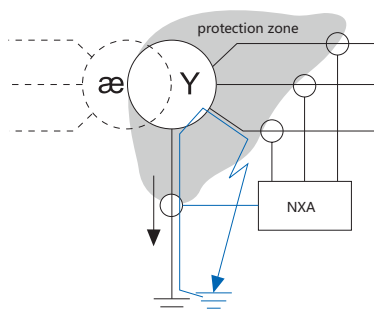

Annex V: Source-changeover controller

Type of controllers

2A type

Being applicable to two-power-supply controllers, having the functions of voltage loss, phase breaking, undervoltage and overvoltage detection as well as automation, time delay, continuous adjustability and conversion for main and auxiliary loop power supplies, as well as the functions of controlling the start/stop of a power generator and electrical interlocking.

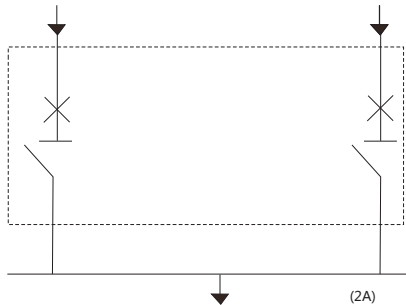

3A type

Being applicable to the condition of 2 input and 1 connect, and having the functions of voltage loss, phase breaking, undervoltage, overvoltage detection and automatic time delay, continuous adjustability and conversion functions as well as electrical interlocking.

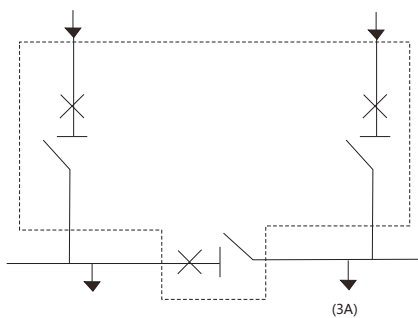

Annex V: Source-changeover controller

Source-changeover controller

Controller	2A	3A
Rated operational voltage (AC440V)	■	■
Rated operational frequency (50/60Hz)	■	■
Types of application		
2 switch transfer (Normal and replacement power supplies)	■	
3 switch transfer (2 input and 1 connect)		■
3 switch transfer (3 power supply transfer)		
Control functions		
Short-time parallel transfer (Only manual operation)		
Start/shut control of a power generator set	■	
Unload and restoration of non-optimal loop	■	■
Remote input		
Transfer time delay	■	■
Two mechanical interlocking accessories	□	
Three mechanical interlocking accessories		□
Standard communication function	■	■
Communication state indication	■	■
Monitor		
Undervoltage (280V-360V)	■	■
Overvoltage (400V-480V)	■	■
Frequency	■	■
Monitoring of parallel switching conditions		
Display		
LCD voltage display and indication lamp	■	■
LCD frequency display	■	■
LCD transfer time-delay display	■	■
Undervoltage fault LED indication	■	■
Overvoltage fault LED indication	■	■
LCD transfer switch indication and indication lamp	■	■
Overall alarm LED indication of transfer failure	■	■
Self-reset model LED indication	■	■
Non-self-reset model LED indication	■	■
Optional automatic transfer mode		
Self-reset	■	■
Non-self-reset	■	■
Selection of manual function	■	■

Annex V: Source-changeover controller

Functions of the controller

2A type display and operation

CD-1: A 2A type source-changeover system is used for the switch between power grids or between the power grid and generator. When a normal power supply does not supply power normally, such as undervoltage, overvoltage, phase breaking, a spare power supply is switched for supplying power. A mechanical interlock component is configured according to standard.

Switch operation zone	Automatic (The system judges the operation automatically, and the light is on when pressing the left upper part)
	Manual (The mechanism is operated by a handle or with buttons S1, S2 and OFF operation)
	S1: load is powered by switching to S1, and the light is on when pressing S1 in the left upper part.
	S2: load is powered by switching to S2, and the light is on when pressing S2 in the left upper part.
	Disconnection: S1, S2 are stripped, and the system load is not powered
Pressing any of buttons S1, S2 and OFF under the automatic condition, the system becomes manual, and corresponding operation is carried out when pressing corresponding buttons.	

2A type of functions

The controller has the following functions

1. Dual-circuit voltage detection display
2. Overvoltage threshold value adjustment: 400V-480V
3. Undervoltage threshold value adjustment: 280V-360V
4. Adjustment of T1, T2, T3 and T4: 0.5-64S with the step size of 0.5S
5. Undervoltage and overvoltage fault indication
6. Power supply fault indication
7. State indication of the circuit breaker
8. Self-input and self-reset or self-input and self-reset selection
9. Manual or automatic selection
10. Comprehensive alarm for transfer failure (fault of the circuit breaker, sending fault of control signals and unmet transfer conditions)
11. All primary adjustment states after resetting and before defaulting
12. Alarm contact
13. Unloading contact
14. Startup contact of a power generator
15. Standard configuration
16. Mechanical interlock
17. The controller has an overvoltage protection function, and operates normally with long-term overvoltage: 130% Ue.

Truth table

S1-circuit power supply	S2-circuit power supply
1	0
0	0
0	1

Annex V: Source-changeover controller

2A action process: power grid-power grid

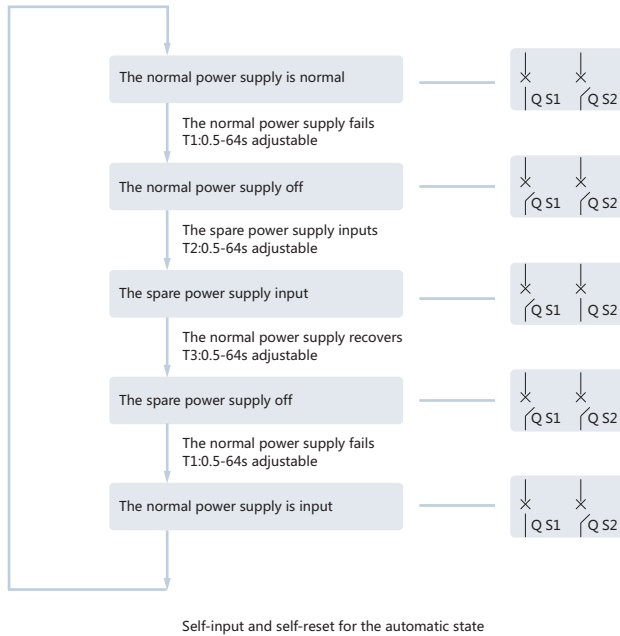

Self-reset of automatic state

- T1: The time before disconnecting QS1 for the fault of the normal power supply
- T2: The time for switching QS2 for the disconnection and unloading of QS1
- T3: The time before disconnecting QS2 for the reset of the normal power supply
- T4: The time before switching QS1 for the disconnection of the QS2 power supply

2A action process: power grid-power grid

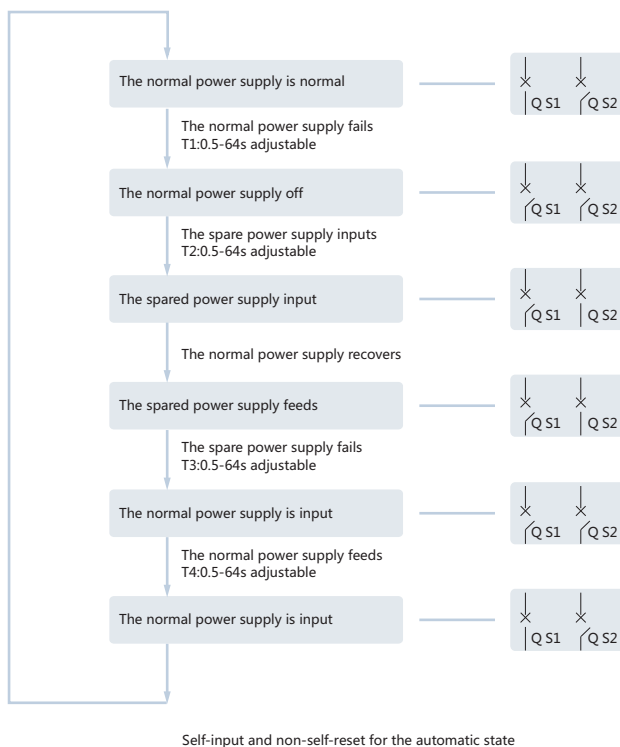

Non-self-reset for the automatic state

- T1: The time before disconnecting QS1 for the fault of the normal power supply
- T2: The time for tripping QS2 for the disconnection and unloading of QS1
- T3: The time before disconnecting QS2 for the fault of the spared power supply
- T4: The time before tripping QS1 for the disconnection of the QS2 power supply

Annex V: Source-changeover controller

2A action process: power grid-power generator

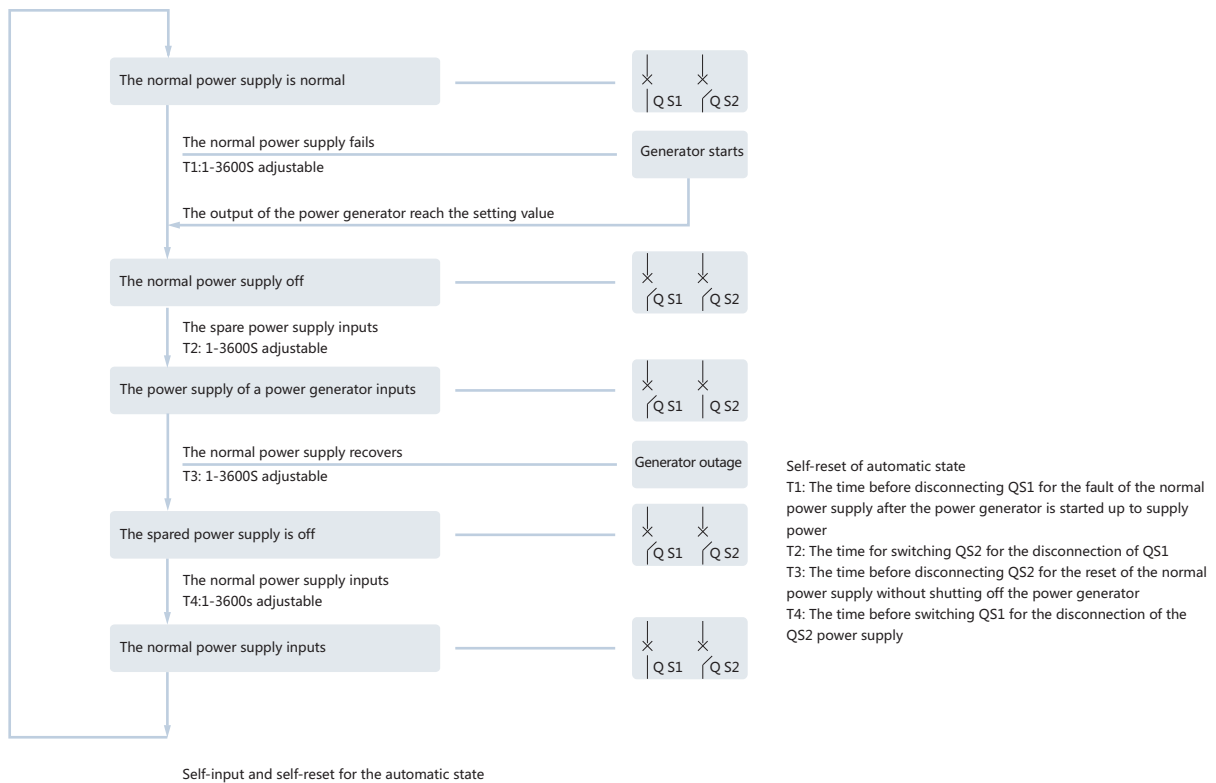

Annex V: Source-changeover controller

3A type display and operation

CD-1 A 3A source-changeover system is applicable to a power supplying system with two power supplies and one buscouple. In the manual operation process, load cannot lead to power interruption, so that the safety running level and the power supplying continuity for power distribution are enhanced. The 3A automatic power supply conversion system is applied to electric places.

Automatic (The system judges the operation automatically, and the light is on when pressing the left upper part)
Manual (The mechanism is operated by a handle or with buttons S1, S2, S1 & S2, S1 & TIE, S2&TIE and OFF operation)
S1: load is powered by switching to S1, the TIE buscouple is tripped, and the light is on at the left upper part when pressing S1.
S2: load is powered by switching to S2, the TIE buscouple is tripped, and the light is on at the left upper part when pressing S2.
S1 & S2: Load is powered by S1 & S2, TIE buscouple is tripped; the light is on at the left upper part when pressing S1 & S2.
S1&TIE: Load is powered by S1, TIE buscouple is tripped; the light is on at the left upper part when pressing S1&TIE
S2&TIE: Load is powered by S2, TIE buscouple is tripped; the light is on at the left upper part when pressing S2&TIE
Disconnection: S1,S2 and TIE are all stripped, and the system load is not powered.
Pressing anyone of buttons S1, S2 S1 & S2, S1&TIE, S2&TIE under the automatic condition, the system becomes manual, and corresponding operation is carried out when pressing corresponding buttons.

3A type functions

The controller has the following functions

1. Dual-circuit voltage detection display
2. Overvoltage threshold value adjustment: 400V-480V
3. Undervoltage threshold value adjustment: 280V-360V
4. Adjustment of T1, T2, T3 and T4: 0.5-64S with the step size of 0.5S
5. Undervoltage and overvoltage fault indication
6. Power supply fault indication
7. State indication of the circuit breaker
8. Self-input and self-reset or self-input and self-reset selection
9. Manual or automatic selection
10. Comprehensive alarm for transfer failure (fault of the circuit breaker, sending fault of control signals and unmet transfer conditions)
11. All primary adjustment states after resetting and before defaulting
12. Alarm contact
13. Unloading function
14. Standard configuration
15. Mechanical interlock
16. The controller has an overvoltage protection function, and operates normally with long-term overvoltage: 130% Ue.

Truth table

S1-circuit power supply	TIE buscouple	S2-circuit power supply
1	0	1
1	1	0
0	1	1
1	0	0
0	0	1
0	0	0

Annex V: Source-changeover controller

3A action process: power grid-power grid

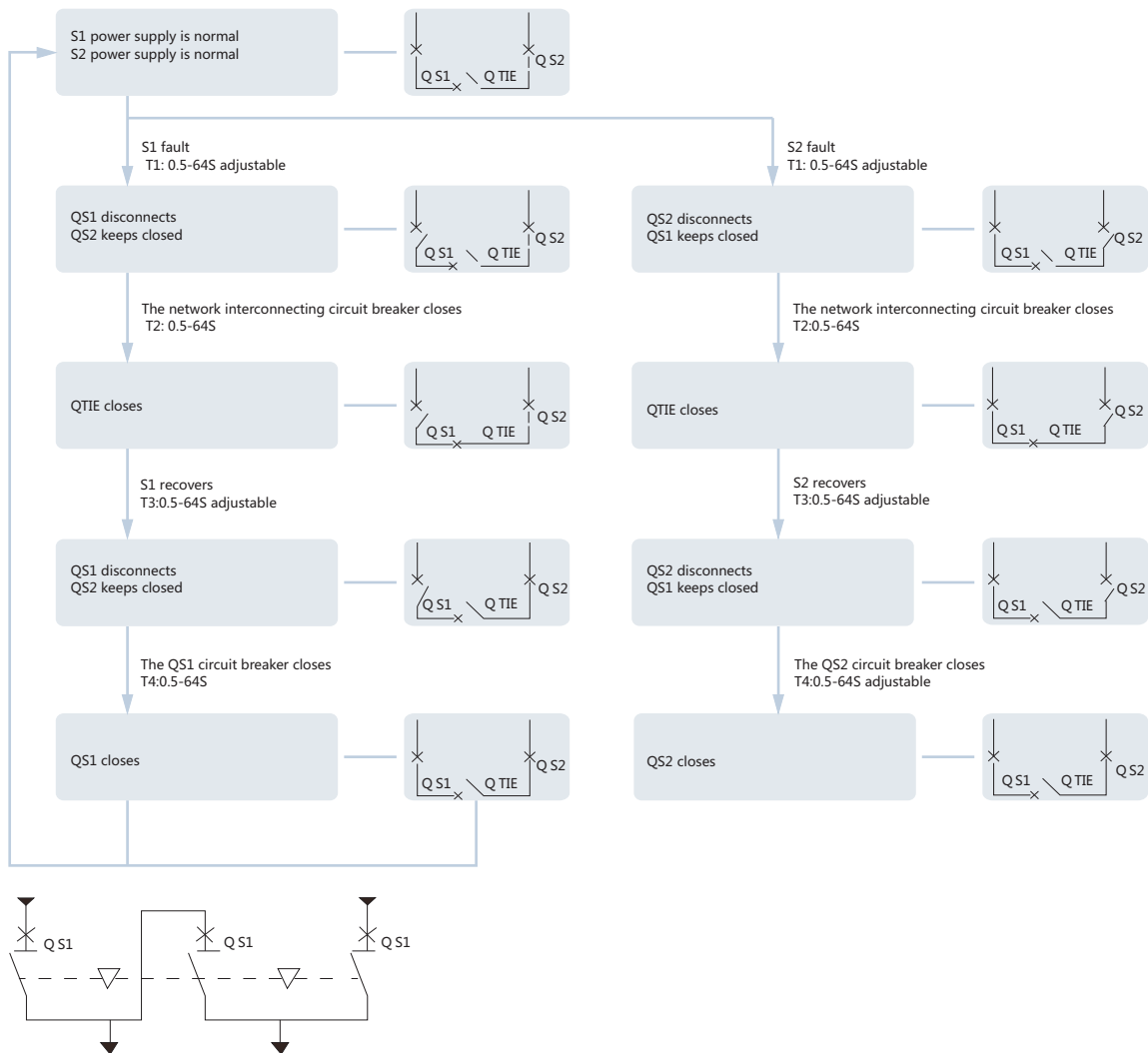

Self-reset of automatic state

T1: The time before disconnecting QS1 for the fault of the S1-circuit power supply (or the time before disconnecting QS2 for the fault of the spared power supply).

T2: The time before the close of QTIE when QS1 is disconnected, namely the time before all load is input for the S2-circuit power supply (or the time before QTIE is closed when QS2 is disconnected, namely the time before all load is input for the S1-circuit power supply).

T3: The time before disconnecting QTIE for the restoration of the S1-circuit power supply (or the time before disconnecting QTIE when the spared power supply is recovered).

T4: The time before the restoration of power supplying for the S1-circuit power supply when QTIE is disconnected, namely the time before the restoration of power supplying for the S1-circuit power supply (the time before the close of QS2 when QTIE is disconnected, namely the time before the restoration of the power supplying of the S2-circuit power supply).

Annex V: Source-changeover controller

3A action process: power grid-power grid

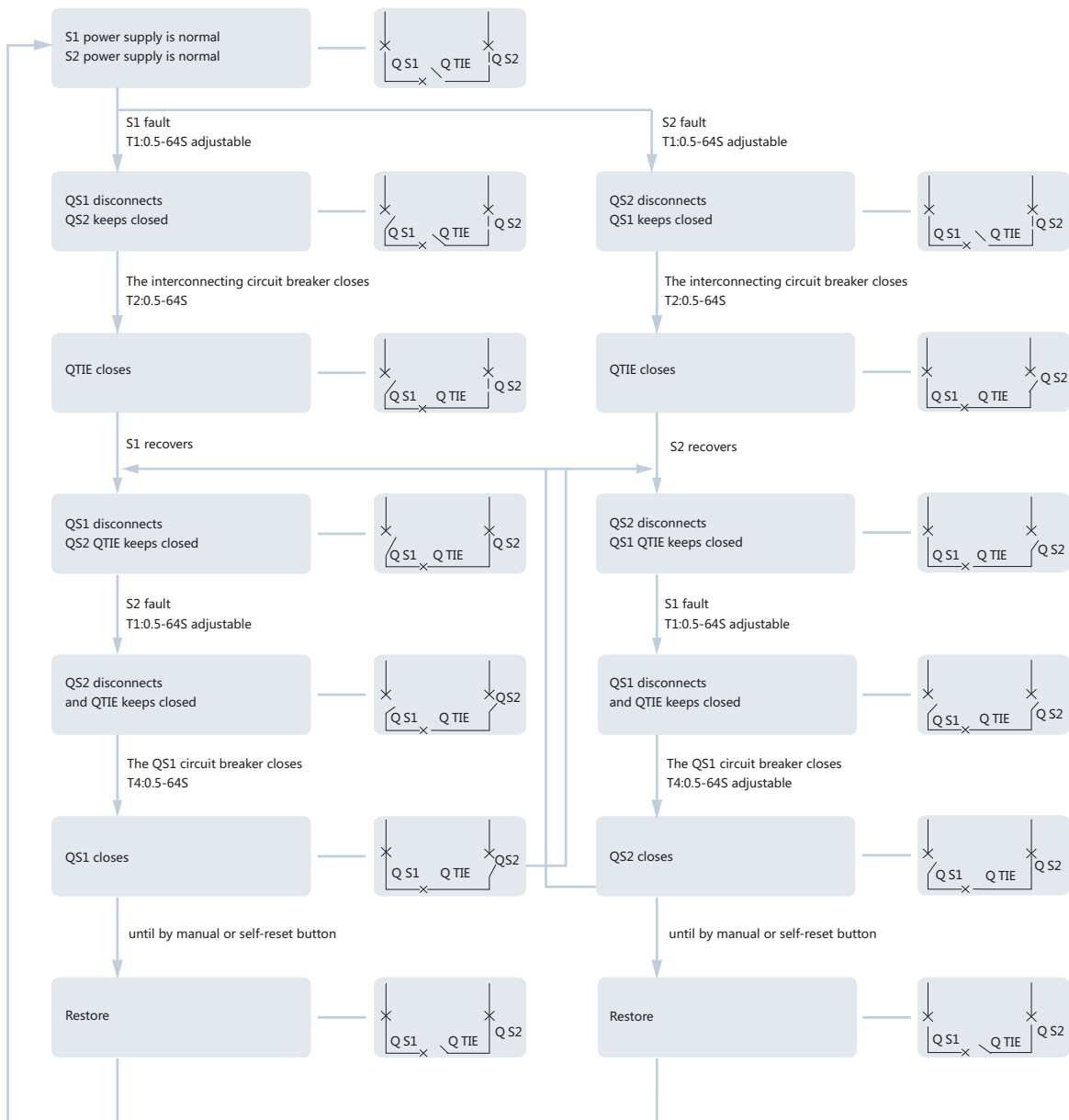

Automatic state-non-self-reset
 Time before disconnecting the fault power supply for one-circuit power supply fault, adjustable at T1: 0.5-64S.
 Time for power supplying time delay for a normal power supply, adjustable at T2: 0.5-64S.